

**SECTION 192 OF THE INCOME-TAX ACT, 1961 - DEDUCTION OF TAX AT SOURCE -  
SALARY - INCOME-TAX DEDUCTION FROM SALARIES UNDER SECTION 192 DURING  
THE FINANCIAL YEAR 2012-13**

**CIRCULAR NO. 8/2012 [F.NO. 275/192/2012-IT(B)], DATED 5-10-2012**

Reference is invited to Circular No. 05/2011, dated 16-8-2011 whereby the rates of deduction of income-tax from the payment of income under the head "Salaries" under Section 192 of the Income-tax Act, 1961 (hereinafter 'the Act'), during the financial year 2011-12, were intimated. The present Circular contains the rates of deduction of income-tax from the payment of income chargeable under the head "Salaries" during the financial year 2012-13 and explains certain related provisions of the Income-tax Act, 1961 (hereinafter the Act) and Income-tax Rules, 1962 (hereinafter the Rules). The relevant Acts, Rules, Forms and Notifications are available at the website of the Income Tax Department-[www.incometaxindia.gov.in](http://www.incometaxindia.gov.in).

**2. RATES OF INCOME-TAX AS PER FINANCE ACT, 2012:**

As per the Finance Act, 2012, income-tax is required to be deducted under Section 192 of the Income-tax Act 1961 from income chargeable under the head "Salaries" for the financial year 2012-13 (i.e. Assessment Year 2013-14) at the following rates:

**2.1 Rates of tax**

**A. Normal Rates of tax:**

<i>Sl. No.</i>	<i>Total Income</i>	<i>Rate of tax</i>
1	Where the total income does not exceed Rs. 2,00,000/-.	<i>Nil</i>
2	Where the total income exceeds Rs. 2,00,000 but does not exceed Rs. 5,00,000/-.	10 per cent of the amount by which the total income exceeds Rs. 2,00,000/-
3	Where the total income exceeds Rs. 5,00,000/- but does not exceed Rs. 10,00,000/-.	Rs. 30,000/- <i>plus</i> 20 per cent of the amount by which the total income exceeds Rs. 5,00,000/-.
4	Where the total income exceeds Rs. 10,00,000/-.	Rs. 1,30,000/- <i>plus</i> 30 per cent of the amount by which the total income exceeds Rs. 10,00,000/-

**B. Rates of tax for every individual, resident in India, who is of the age of sixty years or more but less than eighty years at any time during the financial year:**

<i>Sl. No.</i>	<i>Total Income</i>	<i>Rate of tax</i>
1	Where the total income does not exceed Rs. 2,50,000/-.	<i>Nil</i>
2	Where the total income exceeds Rs. 2,50,000 but does not exceed Rs. 5,00,000/-.	10 per cent of the amount by which the total income exceeds Rs. 2,50,000/-
3	Where the total income exceeds Rs. 5,00,000/- but does not exceed Rs. 10,00,000/-.	Rs. 25,000/- <i>plus</i> 20 per cent of the amount by which the total income exceeds Rs. 5,00,000/-.

4	Where the total income exceeds Rs. 10,00,000/-.	Rs. 1,25,000/- <i>plus</i> 30 per cent of the amount by which the total income exceeds Rs. 10,00,000/-
---	---	--

**C. In case of every individual being a resident in India, who is of the age of eighty years or more at any time during the financial year:**

<i>Sl. No</i>	<i>Total Income</i>	<i>Rate of tax</i>
1	Where the total income does not exceed Rs. 5,00,000/-.	<i>Nil</i>
2	Where the total income exceeds Rs. 5,00,000 but does not exceed Rs. 10,00,000/-.	20 per cent of the amount by which the total income exceeds Rs. 5,00,000/-
3	Where the total income exceeds Rs. 10,00,000/-.	Rs. 1,00,000/- <i>plus</i> 30 per cent of the amount by which the total income exceeds Rs. 10,00,000/-

**2.2 Surcharge on Income tax:**

There will be **no surcharge** on income tax payments by individual taxpayers during FY 2012-13 (AY 2013-14).

**2.3.1 Education Cess on Income tax:**

The amount of income-tax shall be increased by Education Cess on Income Tax at the rate of two per cent of the income-tax.

**2.3.2 Secondary and Higher Education Cess on Income-tax:**

From Financial Year 2007-08 onwards, an additional surcharge is chargeable at the rate of one per cent of income-tax (not including the Education Cess on income-tax).

Education Cess, and Secondary and Higher Education Cess are payable by both resident and nonresident assesseees.

**3. SECTION 192 OF THE INCOME-TAX ACT, 1961: BROAD SCHEME OF TAX DEDUCTION AT SOURCE FROM "SALARIES":**

**3.1 Method of Tax Calculation:**

Every person who is responsible for paying any income chargeable under the head "Salaries" shall deduct income-tax on the estimated income of the assessee under the head "Salaries" for the financial year 2012-13. The income-tax is required to be calculated on the basis of the rates given above subject to provisions of section 206AA of the Act and shall be deducted at the time of each payment. No tax will, however, be required to be deducted at source in any case unless the estimated salary income including the value of perquisites, for the financial year exceeds Rs. 2,00,000/- or Rs.2,50,000/- or Rs. 5,00,000/-, as the case may be, depending upon the age of the employee. (Some typical examples of computation of tax are given at **Annexure-I**).

**3.2 Payment of Tax on Non-monetary Perquisites by Employer:**

An option has been given to the employer to pay the tax on non-monetary perquisites given to an employee. The employer may, at his option, make payment of the tax on such perquisites himself without making any TDS from the salary of the employee. The employer will have to pay such tax at the time when such tax was otherwise deductible *i.e.* at the time of payment of income chargeable under the head

"salaries" to the employee.

### 3.3 Computation of Average Income Tax:

For the purpose of making the payment of tax mentioned in para 3.2 above, tax is to be determined at the average of income-tax computed on the basis of rate in force for the financial year, on the income chargeable under the head "salaries", including the value of perquisites for which tax has been paid by the employer himself.

#### ILLUSTRATION:

Suppose that the income chargeable under the head "salaries" of an employee below sixty years of age for the year inclusive of all perquisites is Rs. 4,50,000/-, out of which, Rs. 50,000/- is on account of non-monetary perquisites and the employer opts to pay the tax on such perquisites as per the provisions discussed in para 3.2 above.

#### STEPS:

Income Chargeable under the head "Salaries" inclusive of all perquisites	Rs. 4,50,000/-
Tax on Total Salaries(including Cess)	Rs. 25,750/-
Average Rate of Tax $[(25,750/4,50,000) \times 100]$	5.72%
Tax payable on Rs.50,000/= (5.72% of 50,000)	Rs. 2,861/-
Amount required to be deposited each month	Rs. 240 (Rs. 238.4) (=2061/12)

The tax so paid by the employer shall be deemed to be TDS made from the salary of the employee.

### 3.4 Salary From More Than One Employer:

Section 192(2) deals with situations where an individual is working under more than one employer or has changed from one employer to another. It provides for deduction of tax at source by such employer (as the taxpayer may choose) from the aggregate salary of the employee who is or has been in receipt of salary from more than one employer. The employee is now required to furnish to the present/chosen employer details of the income under the head "Salaries" due or received from the former/other employer and also tax deducted at source therefrom, in writing and duly verified by him and by the former/other employer. The present/ chosen employer will be required to deduct tax at source on the aggregate amount of salary (including salary received from the former or other employer).

### 3.5 Relief When Salary Paid in Arrear or Advance:

**3.5.1** Under section 192(2A) where the assessee, being a Government servant or an employee in a company, co-operative society, local authority, university, institution, association or body is entitled to the relief under Section 89(1) he may furnish to the person responsible for making the payment referred to in Para (3.1), such particulars in Form No. 10E duly verified by him, and thereupon the person responsible, as aforesaid, shall compute the relief on the basis of such particulars and take the same into account in making the deduction under Para(3.1) above.

Here "University means a University established or incorporated by or under a Central, State or Provincial Act, and includes an institution declared under section 3 of the University Grants Commission Act, 1956(3 of 1956), to be University for the purposes of the Act.

**3.5.2** With effect from 1-4-2010 (AY 2010-11), no such relief shall be granted in respect of any amount received or receivable by an assessee on his voluntary retirement or termination of his service, in accordance with any scheme or schemes of voluntary retirement or in the case of a public sector company referred to in section 10(10C)(i) (read with Rule 2BA), a scheme of voluntary separation, if an exemption

in respect of any amount received or receivable on such voluntary retirement or termination of his service or voluntary separation has been claimed by the assessee under section 10(10C) in respect of such, or any other, assessment year.

**3.6 Income under any Other head:** (i) Section 192(2B) enables a taxpayer to furnish particulars of income under any head other than "Salaries" ( not being a loss under any such head other than the loss under the head " income from house property") received by the assessee for the same financial year and of any tax deducted at source thereon. Form no. 12C, which was earlier prescribed for furnishing such particulars, has since been omitted from the Rules by the Income Tax (24th amendment) Rules, 2003, w.e.f. 1-10-2003. However, the particulars may now be furnished in a simple statement, which is properly signed and verified by the taxpayer in the manner as prescribed under Rule 26B(2) of the Rules and shall be annexed to the simple statement. The form of verification is reproduced as under:

**I, \_\_\_\_\_ (name of the assessee), do declare that what is stated above is true to the best of my information and belief.**

(ii) Such income should not be a loss under any such head other than the loss under the head "Income from House Property" for the same financial year. DDO shall take such other income and tax deducted at source, if any, on such income and the loss, if any, under the head "Income from House Property" into account for the purpose of computing tax deductible in terms of section 192(2B) of the Act. However, this sub-section shall not in any case have the effect of reducing the tax deductible (except where the loss under the head "Income from House Property" has been taken into account) from income under the head "Salaries" below the amount that would be so deductible if the other income and the tax deducted thereon had not been taken into account'. In other words, the DDO can take into account any loss (negative income) only under the head "income from House Property" and no other head for working out the amount of total tax to be deducted.

(iii) Section 192(2C) lays down that a person responsible for paying any income chargeable under the head "salaries" shall furnish to the person to whom such payment is made a statement giving correct and complete particulars of perquisites or profits in lieu of salary provided to him and the value thereof in Form 12BA (**Annexure-II**). Form 12BA along with Form 16, as issued by the employer, are required to be produced on demand before the Assessing Officer in terms of Section 139C of the Act.

### **3.7 Computation of income under the head "Income from house property":**

While taking into account the loss from House Property, the DDO shall ensure that the employee files the declaration referred to above and encloses therewith a computation of such loss from House Property. Following details shall be obtained and kept by the employer in respect of loss claimed under the head "Income from house property" separately for each house property:

- (a) Gross annual rent/value
- (b) Municipal Taxes paid, if any
- (c) Deduction claimed for interest paid, if any
- (d) Other deductions claimed
- (e) Address of the property
- (f) Amount of loan, if any; and
- (g) Name and address of the lender (loan provider)

#### **3.7.1 Conditions for Claim of Deduction of Interest on Borrowed Capital for Computation of Income From House Property Section 24(b):**

Section 24(b) of the Act allows deduction from income from house property on interest on borrowed capital as under:-

- (i) the deduction is allowed only in case of house property which is owned and in the occupation of the employee for his own residence. However, if it is not actually occupied by the employee in view of his place of the employment being at other place, his residence in that other place should not be in a building belonging to him.
- (ii) The quantum of deduction allowed as per table below:

<i>Sl. No</i>	<i>Purpose of borrowing capital</i>	<i>Date of borrowing capital</i>	<i>Maximum Deduction allowable</i>
1	Repair or renewal or reconstruction of the house	Any time	Rs. 30,000/-
2	Acquisition or construction of the house	Before 01.04.1999	Rs. 30,000/-
3	Acquisition or construction of the house	On or after 01.04.1999	Rs. 1,50,000/-

In case of Serial No. 3 above

- (a) The house so acquired or constructed should be completed within 3 years from the end of the FY in which the capital was borrowed. Hence it is necessary for the DDO to have the completion certificate of the house property against which deduction is claimed either from the builder or through self-declaration from the employee.
- (b) Further any prior period interest for the FYs up to the FY in which the property was acquired and constructed shall be deducted in equal instalments for the FY in question and subsequent four FYs.
- (c) The employee has to furnish before the DDO a certificate from the person to whom any interest is payable on the borrowed capital specifying the amount of interest payable. In case a new loan is taken to repay the earlier loan, then the certificate should also show the comprehensive picture of Principal and Interest of the loan so repaid.

### **3.8 Adjustment for Excess or Shortfall of Deduction:**

The provisions of Section 192(3) allow the deductor to make adjustments for any excess or shortfall in the deduction of tax already made during the financial year, in subsequent deductions for that employee within that financial year itself.

### **3.9 Salary Paid in Foreign Currency:**

For the purposes of deduction of tax on salary payable in foreign currency, the value in rupees of such salary shall be calculated at the "Telegraphic transfer buying rate" of such currency as on the date on which tax is required to be deducted at source( see Rule 26).

## **4. PERSONS RESPONSIBLE FOR DEDUCTING TAX AND THEIR DUTIES:**

**4.1** Section 204 (i) of the Act the "persons responsible for paying" for the purpose of Section 192 means the employer himself or if the employer is a Company, the Company itself including the Principal Officer thereof. Further, as per Section 204(iv), in the case of credit, or as the case may be, if the payment is by or on behalf of Central Government or State Government, the DDO or any other person by whatever name called, responsible for crediting, or as the case may be, paying such sum is the "persons responsible for paying".

**4.2** The tax determined as per para 8 should be deducted from the salary u/s 192 of the Act.

### 4.3. Deduction of Tax at Lower Rate:

If the jurisdictional TDS officer of the Taxpayer issues a certificate of No Deduction or Low Deduction of Tax under section 197 of the Income Tax Act, subsequent to the application filed before him in Form No 13 by the Taxpayer; then the DDO should take into account such certificate and deduct tax on the salary payable at the rates mentioned therein. (see Rule 28AA).

### 4.4. Deposit of Tax Deducted:

Rule 30 prescribes time and mode of payment of tax deducted at source to the account of Central Government.

**4.4.1.** Prescribed time of payment/deposit of TDS made to the credit of Central Government account is as under:

(a) In case of an Office of Government:

<i>Sl. No.</i>	<i>Description</i>	<i>Time up to which to be deposited.</i>
1	Tax deposited without Challan [Book Entry]	SAME DAY
2	Tax deposited with Challan	7TH DAY NEXT MONTH
3	Tax on perquisites opt to be deposited by the employer.	7TH DAY NEXT MONTH

(b) In any case other than an Officer of Government

<i>Sl. No.</i>	<i>Description</i>	<i>Time up to which to be deposited.</i>
1	Tax deductible in March	30th APRIL NEXT FINANCIAL YEAR
2	Tax deductible in any other month	7TH DAY NEXT MONTH
3	Tax on perquisites opt to be deposited by the employer	7TH DAY NEXT MONTH

However, if a DDO applies before the jurisdictional Additional/Joint Commissioner of Income Tax to permit quarterly payments of TDS under section 192, the Rule 30(3) allow for payments on quarterly basis and time given in Table below:

<i>Sl. No.</i>	<i>Quarter to the financial year ended on</i>	<i>Date for quarterly payment</i>
1	30th June	7th July
2	30th September	7th October
3	31st December	7th January
4	31st March	30th April next Financial Year

### 4.4.2 Mode of Payment of TDS

#### 4.4.2.1 Payment by Book Entry:

In the case of an office of the Government, where tax has been paid to the credit of the Central Government without the production of a challan [Book Entry], the Pay and Accounts Officer or the Treasury Officer or the Cheque Drawing and Disbursing Officer or any other person by whatever name called to whom the deductor reports the tax so deducted and who is responsible for crediting such sum to the credit of the Central Government, shall-

- (a) submit a statement in Form No. 24G within ten days from the end of the month to the agency authorized by the Director General of Income-tax (Systems) [TIN Facilitation Centres currently

managed by M/s National Securities Depository Ltd.] in respect of tax deducted by the deductors and reported to him for that month; and

- (b) intimate the number (hereinafter referred to as the Book Identification Number or BIN) generated by the agency to each of the deductors in respect of whom the sum deducted has been credited. BIN consist of receipt number of Form 24G, DDO sequence number and date on which tax is deposited.

The procedure of furnishing Form 24G is detailed in Annexure IV. PAOs/DDOs should go through the FAQs therein to understand the correct process to be followed.

#### **4.4.2.2 Payment by an Income Tax Challan:**

- (i) In such a case the amount of tax so deducted shall be deposited to the credit of the Central Government by remitting it within the time specified in Table 4.4.1 above into any branch of the Reserve Bank of India or of the State Bank of India or of any authorized bank;
- (ii) In case of a company and a person (other than a company), to whom provisions of section 44AB are applicable, the amount deducted shall be electronically remitted into the Reserve Bank of India or the State Bank of India or any authorised bank accompanied by an electronic income-tax challan.

The amount shall be *construed as electronically remitted* to the Reserve Bank of India or to the State Bank of India or to any authorized bank, if the amount is remitted by way of:

- (a) internet banking facility of the Reserve Bank of India or of the State Bank of India or of any authorized bank; or
- (b) debit card (Notification No.41/2010, dated 31st May, 2010)

#### **4.5 Interest, Fee, Penalty & Prosecution for Failure to Deposit Tax Deducted:**

If a person fails to deduct the whole or any part of the tax at source, or, after deducting, fails to pay the whole or any part of the tax to the credit of the Central Government within the prescribed time as under:

**4.5.1** He shall be liable to action in accordance with the provisions of section 201. Section 201(1A) lays down that such person shall be liable to pay simple interest

- (i) at 1% for every month or part of the month on the amount of such tax from the date on which such tax was deductible to the date on which such tax is deducted and
- (ii) at one and one-half per cent for every month or part of a month on the amount of such tax from the date on which such tax was deducted to the date on which such tax is actually paid.

Such interest, if chargeable, is mandatory in nature and has to be paid before furnishing of quarterly statement of TDS for respective quarter.

**4.5.2** Section 271C lays down that if any person fails to deduct whole or any part of tax at source or fails to pay the whole or part of tax deducted, he shall be liable to pay, by way of penalty, a sum equal to the amount of tax not deducted or paid by him.

**4.5.3** Further, section 276B lays down that if a person fails to pay to the credit of the Central Government within the prescribed time, as above, the tax deducted at source by him, he shall be punishable with rigorous imprisonment for a term which shall be between 3 months and 7 years, along fine.

#### **4.6 Furnishing of Certificate for Tax Deducted (Section 203):**

**4.6.1** Section 203 requires the DDO to furnish to the employee a certificate in Form 16 detailing the amount of TDS and certain other particulars. The Act stipulates that the Form 16 should be furnished to

the employee by 31st May after the end of the financial year in which the income was paid and tax deducted. Even the banks deducting tax at the time of payment of pension are required to issue such certificates. Revised Form 16 annexed to Notification dated 31-5-2010 is enclosed. The certificate in Form 16 shall specify

- (a) Valid permanent account number (PAN) of the deductee;
- (b) Valid tax deduction and collection account number (TAN) of the deductor;
- (c) (i) Book identification number or numbers (BIN) where deposit of tax deducted is without production of challan in case of an office of the Government;  
(ii) Challan identification number or numbers (CIN\*) in case of payment through bank.
- (d) Receipt numbers of all the relevant quarterly statements in case the statement referred to in clause (i) is for tax deducted at source from income chargeable under the head "Salaries". The receipt number of the quarterly statement is of 8 digit.

**It may be noted that under the new TDS procedure, the accuracy and availability of TAN, PAN and receipt number of TDS statement filed by the deductor will be unique identifier for granting online credit for TDS. Hence due care should be taken in filling these particulars.**

Due care should be also be taken in indicating correct CIN/ BIN in TDS certificate.

If the DDO fails to issue these certificates to the person concerned, as required by section 203, he will be liable to pay, by way of penalty, under section 272A(2)(g), a sum which shall be Rs. 100/-for every day during which the failure continues.

It is, however, clarified that there is no obligation to issue the TDS certificate in case tax at source is not deductible/deducted by virtue of claims of exemptions and deductions.

**4.6.2** If an assessee is employed by more than one employer during the year, each of the employers shall issue Part A of the certificate in Form No. 16 pertaining to the period for which such assessee was employed with each of the employers and Part B may be issued by each of the employers or the last employer at the option of the assessee.

**4.6.3** The employer may issue a duplicate certificate in Form No. 16 if the deductee has lost the original certificate so issued and makes a request for issuance of a duplicate certificate and such duplicate certificate is certified as duplicate by the deductor.

#### **4.6.4. Authentication by Digital Signatures:**

- (i) Where a certificate is to be furnished in Form No. 16, the deductor may, at his option, use digital signatures\*\* to authenticate such certificates.
- (ii) In case of certificates issued under clause (i), the deductor shall ensure that
  - (a) the conditions prescribed in para 4.6.1 above are complied with;
  - (b) once the certificate is digitally signed, the contents of the certificates are not amenable to change; and
  - (c) the certificates have a control number and a log of such certificates is maintained by the deductor.

Challan identification number (CIN) means the number comprising the Basic Statistical Returns (BSR) Code of the Bank branch where the tax has been deposited, the date on which the tax has been deposited



and challan serial number given by the bank.

- The digital signature is being used to authenticate most of the e-transactions on the internet as transmission of information using digital signature is failsafe. It saves time specially in organisations having large number of employees where issuance of certificate of deduction of tax with manual signature is time consuming (Circular no. 2 of 2007, dated 21-5-2007)

#### **4.6.5. Furnishing of particulars pertaining to perquisites, etc (Section 192(2C)):**

**4.6.5.1** As per section 192(2C), the responsibility of providing correct and complete particulars of perquisites or profits in lieu of salary given to an employee is placed on the person responsible for paying such income i.e., the person responsible for deducting tax at source. The form and manner of such particulars are prescribed in Rule 26A, Form 12BA and Form 16 of the Rules. Information relating to the nature and value of perquisites is to be provided by the employer in Form 12BA in case salary paid or payable is above Rs.2,00,000/-. In other cases, the information would have to be provided by the employer in Form 16 itself.

**4.6.5.2** An employer, who has paid the tax on perquisites on behalf of the employee as per the provisions discussed in paras 3.2 and 3.3 of this circular, shall furnish to the employee concerned, a certificate to the effect that tax has been paid to the Central Government and specify the amount so paid, the rate at which tax has been paid and certain other particulars in the amended Form 16.

**4.6.5.3** The obligation cast on the employer under Section 192(2C) for furnishing a statement showing the value of perquisites provided to the employee is a crucial responsibility of the employer, which is expected to be discharged in accordance with law and rules of valuation framed there under. Any false information, fabricated documentation or suppression of requisite information will entail consequences thereof provided under the law. The certificates in Forms 16 and/or Rule 12BA specified above, shall be furnished to the employee by 31st May of the financial year immediately following the financial year in which the income was paid and tax deducted. If he fails to issue these certificates to the person concerned, as required by section 192(2C), he will be liable to pay, by way of penalty, under section 272A(2)(i), a sum which shall be Rs. 100/- for every day during which the failure continues.

#### **4.7 Mandatory Quoting of PAN and TAN:**

**4.7.1** Section 203A of the Act makes it obligatory for all persons responsible for deducting tax at source to obtain and quote the Tax-deduction Account No (TAN) in the challans, TDS- certificates, statements and other documents. Detailed instructions in this regard are available in this Department's Circular No.497 [F.No.275/118/87-IT(B), dated 9-10-1987]. If a person fails to comply with the provisions of section 203A, he will be liable to pay, by way of penalty, under section 272BB, a sum of ten thousand rupees. Similarly, as per Section 139A(5B), it is obligatory for persons deducting tax at source to quote PAN of the persons from whose income-tax has been deducted in the statement furnished u/s 192(2C), certificates furnished u/s 203 and all returns prepared and delivered as per the provisions of section 200(3) of the Act.

**4.7.2** All tax deductors are required to file the TDS returns in Form No.24Q (for tax deducted from salaries). As the requirement of filing TDS/TCS certificates, by the employee along with the return of income, has been done away with, the lack of PAN of deductees is creating difficulties in giving credit for the tax deducted. Tax deductors and tax collectors are, therefore, advised to quote correct PAN details of all deductees in the TDS returns for salaries in Form 24Q. Taxpayers liable to TDS are also advised to furnish their correct PAN with their deductors. It may be noted that non-furnishing of PAN by the deductee (employee) to the deductor (employer) will result in deduction of TDS at higher rates u/s 206AA of the Act mentioned in para 4.8 below.

#### **4.8 Compulsory Requirement to furnish PAN by employee (Section 206AA):**

**4.8.1** Section 206AA in the Act makes furnishing of PAN by the employee compulsory in case of receipt of any sum or income or amount, on which tax is deductible. If employee (deductee) fails to furnish

his/her PAN to the deductor, the deductor has been made responsible to make TDS at higher of the following rates:

- (i) at the rate specified in the relevant provision of this Act; or
- (ii) at the rate or rates in force; or
- (iii) at the rate of twenty per cent.

The deductor has to determine the tax amount in all the three conditions and apply the higher rate of TDS. However, where the income of the employee computed for TDS u/s 192 is below taxable limit, no tax will be deducted. But where the income of the employee computed for TDS u/s 192 is above taxable limit, the deductor will calculate the average rate of income-tax based on rates in force as provided in sec 192. If the tax so calculated is below 20%, deduction of tax will be made at the rate of 20% and in case the average rate exceeds 20%, tax is to be deducted at the average rate. Education cess @ 2% and Secondary and Higher Education Cess @ 1% is not to be deducted, in case the TDS is deducted at 20% u/s 206AA of the Act.

#### **4.9 Statement of deduction of tax under section 200(3) [Quarterly Statement of TDS]:**

**4.9.1.** The person deducting the tax (employer in case of salary income), is required to file duly verified Quarterly Statements of TDS in Form 24Q for the periods [details in Table below] of each financial year, to the Director General of Income Tax (Systems), ARA centre, Jhandewalan Extn., New Delhi or TIN/facilitation Centres authorized by DGIT (System's) which is currently managed by M/s National Securities Depository Ltd. (NSDL). The requirement of filing an annual return of TDS has been done away with w.e.f. 1-4-2006. The quarterly statement for the last quarter filed in Form 24Q (as amended by Notification No. S.O.704(E), dated 12-5-2006) shall be treated as the annual return of TDS. Due dates of filing this statement quarterwise is as in the Table below.

**TABLE: Dates of filing Quarterly Statements E-TDS Return 24Q**

<i>Sl. No</i>	<i>Return for Quarter ending</i>	<i>Due date for Government Offices</i>	<i>Due date for Other Deductors</i>
1	30th June	31st July	15th July
2	30th September	31st October	15th October
3	31st December	31st January	15th January
4	31st March	15th May	15th May

**4.9.2.** The statements referred above may be furnished in paper form or electronically in accordance with the procedures, formats and standards specified by the Director General of Income-tax (Systems) along with the verification of the statement in Form 27 A.

**4.9.3.** All Returns in Form 24Q are required to be furnished in computer media except in case where the number of deductee records is less than 20. This is in accordance with the "Electronic Filing of Returns of Tax Deducted at Source Scheme, 2003" as notified vide Notification No. S.O. 974 (E), dated 26-8-2003 read with Notification No. SO 1261(E), dated 31-5-2010. Deductors have to file quarterly statements with the e-TDS Intermediary at any of the TIN Facilitation Centres, particulars of which are available at <http://www.incometaxindia.gov.in> and at <http://tin-nsdl.com>.

#### **4.9.4 Fee for default in furnishing statements (Section 234E):**

If a person fails to deliver or caused to be delivered a statement within the time prescribed in Section 200(3) in respect of tax deducted at source on or after 1-7-2012 he shall be liable to pay, by way of fee a sum of Rs. 200 for every day during which the failure continues. However, the amount of such fee shall not exceed the amount of tax which was deductible at source. This fee is mandatory in nature and to be

paid before furnishing of such statement.

#### **4.9.5 Penalty for failure in furnishing statements (section 271H):**

If a person fails to deliver or caused to be delivered a statement within the time prescribed in section 200(3) in respect of tax deducted at source on or before 30-6-2012, he shall be liable to pay, by way of penalty, a sum of Rs. 100 for every day during which the failure continues, [section 272A(2)(k)]. However, the amount of such fee shall not exceed the amount of tax which was deductible at source.

If a person fails to deliver or caused to be delivered a statement within the time prescribed in section 200(3) in respect of tax deducted at source on or after 1-7-2012, he shall be liable to pay, by way of penalty a sum which shall not be less than Rs. 10,000/- but which may extend to Rs 1,00,000/-. However, the penalty shall not be levied if the person proves that after paying TDS with the fee and interest, if any, to the credit of Central Government, he had delivered such statement before the expiry of one year from the time prescribed for delivering the statement.

#### **4.9.6 Penalty for furnishing incorrect information (section 271H)**

If a person furnishes incorrect information in the statement in respect of tax deducted at source on or after 1-7-2012, he shall be liable to pay penalty which shall not be less than Rs. 10,000/- but which may extend to Rs. 1,00,000/-.

#### **4.9.7. At the time of preparing statements of tax deducted, the deductor is required to mandatorily quote:**

- (i) his tax deduction and collection account number (TAN) in the statement;
- (ii) quote his permanent account number (PAN) in the statement except in the case where the deductor is an office of the Government including State Government). In case of Government deductors "PANNOTREQD" to be quoted in the e-TDS statement;
- (iii) quote the permanent account number PAN of all deductees;
- (iv) furnish particulars of the tax paid to the Central Government including book identification number or challan identification number, as the case may be.
- (v) furnish particular of amounts paid or credited on which tax was not deducted in view of the issue of certificate of no deduction of tax u/s 197 by the assessing officer of the payee.

#### **4.10 TDS on Income from Pension:**

In the case of pensioners who receive their pension from a nationalized bank, the instructions contained in this circular shall apply in the same manner as they apply to salary-income. The deductions from the amount of pension under section 80C on account of contribution to Life Insurance, Provident Fund, NSC etc., if the pensioner furnishes the relevant details to the banks, may be allowed. Necessary instructions in this regard were issued by the Reserve Bank of India to the State Bank of India and other nationalized Banks vide RBI's Pension Circular(Central Series) No.7/C.D.R./1992 (Ref. CO: DGBA: GA (NBS) No.60/GA.64(11 CVL)-/92), dated the 27th April, 1992, and, these instructions should be followed by all the branches of the Banks, which have been entrusted with the task of payment of pensions. Further all branches of the banks are bound u/s 203 to issue certificate of tax deducted in Form 16 to the pensioners also vide CBDT circular no. 761, dated 13-1-1998.

#### **4.11 New Pension Scheme:**

The New Pension Scheme(NPS) has become operational since 1st Jan. 2004 and is mandatory for all new recruits to the Central Government Services from 1st January, 2004. Since then it has been opened to employees of State Governments, Private Sector and Self Employed. The income received by the NPS

trust is exempt. The NPS trust is exempted from the Dividend Distribution Tax and is also exempted from the Securities Transaction Tax on all purchases and sales of equities and derivatives. The NPS trust will also receive income without tax deduction at source. The above amendments are retrospectively effective from 1-4-2009 (AY 2009-10) onwards.

#### **4.12. Matters pertaining to the TDS made in case of Non-Resident:**

**4.12.1** Where Non-Residents are deputed to work in India and taxes are borne by the employer, if any refund becomes due to the employee after he has already left India and has no bank account in India by the time the assessment orders are passed, the refund can be issued to the employer as the tax has been borne by it [Circular No. 707, dated 11-7-1995].

**4.12.2** In respect of non-residents, the salary paid for services rendered in India shall be regarded as income earned in India. It has been specifically provided in the Act that any salary payable for rest period or leave period which is both preceded or succeeded by service in India and forms part of the service contract of employment will also be regarded as income earned in India.

### **5. Computation of Income Under the Head "Salaries"**

#### **5.1 Income chargeable under the head "Salaries":**

(1) The following income shall be chargeable to income-tax under the head "Salaries" :

- (a) any salary due from an employer or a former employer to an assessee in the previous year, whether paid or not;
- (b) any salary paid or allowed to him in the previous year by or on behalf of an employer or a former employer though not due or before it became due to him.
- (c) any arrears of salary paid or allowed to him in the previous year by or on behalf of an employer or a former employer, if not charged to income-tax for any earlier previous year.

(2) For the removal of doubts, it is clarified that where any salary paid in advance is included in the total income of any person for any previous year it shall not be included again in the total income of the person when the salary becomes due.

Any salary, bonus, commission or remuneration, by whatever name called, due to, or received by, a partner of a firm from the firm shall not be regarded as "Salary".

#### **5.2 Definition of "Salary", "perquisite" and "profit in lieu of salary" (Section 17):**

##### **5.2.1 "Salary" includes:-**

- i.* wages, fees, commissions, perquisites, profits in lieu of, or, in addition to salary, advance of salary, annuity or pension, gratuity, payments in respect of encashment of leave etc.
- ii.* the portion of the annual accretion to the employee's account in to the balance credit of the employee participating in a recognized provident fund as consists of { Rule 6 of Part A of the Fourth Schedule of the Act} :
  - (a) Contributions made by the employer to the account of the employee in a recognized provident fund in excess of 12% of the salary of the employee,
  - (b) Interest credited on the balance to the credit of the employee in so far as it is allowed at a rate exceeding such rate as may be fixed by Central Government. [w.e.f. 1-9-2010 rate is fixed at 9.5% - Notification No. SO 1046(E), dated 13-5-2011]

- iii. Any contribution made by the Central Government or any other employer to the account of the employee under the New Pension Scheme as notified *vide* Notification F.N. 5/7/2003-ECB&PR, dated 22-12-2003 (enclosed as Annexure) referred to in section 80CCD (para 5.4(C) of this Circular) shall also be included in the salary income.

It may be noted that, since salary includes pensions and tax at source would have to be deducted from pension also, if otherwise called for. However, no tax is required to be deducted from the commuted portion of pension to the extent exempt under section 10 (10A).

Family Pension is chargeable to tax under head 'income from other sources' and not under the head 'salary'. Therefore, provisions of section 192 of the Act are not applicable.

### 5.2.2 Perquisite includes:

- I. The value of rent free accommodation provided to the employee by his employer;
- II. The value of any concession in the matter of rent in respect of any accommodation provided to the employee by his employer;
- III. The value of any benefit or amenity granted or provided free of cost or at concessional rate in any of the following cases:
  - (i) By a company to an employee who is a director of such company;
  - (ii) By a company to an employee who has a substantial interest in the company;
  - (iii) By an employer (including a company) to an employee, who is not covered by (i) or (ii) above and whose income under the head 'Salaries' (whether due from or paid or allowed by one or more employers), exclusive of the value of all benefits and amenities not provided by way of monetary payment, exceeds Rs.50,000/-.

[What constitutes concession in the matter of rent have been prescribed in *Explanation 1* to 4 below section 17(2)(ii) of the Income Tax Act, 1961]

- IV. Any sum paid by the employer in respect of any obligation which would have been paid by the assessee.
- V. Any sum payable by the employer, whether directly or through a fund, other than a recognized provident fund or an approved superannuation fund or other specified funds u/s 17, to effect an assurance on the life of an assessee or to effect a contract for an annuity.
- VI. With effect from 1-4-2010 (AY 2010-11) it is further clarified that the value of any specified security or sweat equity shares allotted or transferred, directly or indirectly, by the employer, or former employer, free of cost or at concessional rate to the assessee, shall constitute a perquisite in the hand of employees.

Here

- (a) "specified security" means the securities as defined in section 2(h) of the Securities Contracts (Regulation) Act, 1956 (42 of 1956) and, where employees' stock option has been granted under any plan or scheme therefore, includes the securities offered under such plan or scheme;
- (b) "sweat equity shares" means equity shares issued by a company to its employees or directors at a discount or for consideration other than cash for providing know-how or making available rights in the nature of intellectual property rights or value additions, by whatever name called;

- (c) the value of any specified security or sweat equity shares shall be the fair market value of the specified security or sweat equity shares, as the case may be, on the date on which the option is exercised by the assessee as reduced by the amount actually paid by, or recovered from the assessee in respect of such security or shares;
- (d) "fair market value" means the value determined in accordance with the method as may be prescribed;
- (e) "option" means a right but not an obligation granted to an employee to apply for the specified security or sweat equity shares at a predetermined price;

VII. The amount of any contribution to an approved superannuation fund by the employer in respect of the assessee, to the extent it exceeds one lakh rupees; and

VIII The value of any other fringe benefit or amenity as may be prescribed.

**5.2.2A** Rules for valuation of perquisite are as under : -

**5.2.2A.1 Non-Monetary perquisites:** Non-monetary benefits are those that are not provided by way of monetary payments to the employees

**I. Residential Accommodation provided by the employer:-**

"Accommodation" includes a house, flat, farm house, hotel accommodation, motel, service apartment, guest house, a caravan, mobile home, ship etc.

A. Valuation of the perquisite of rent free unfurnished accommodation, all employees are divided into two categories:

- (i) For employees of the Central and State Governments the value of perquisite shall be equal to the licence fee charged for such accommodation as reduced by the rent actually paid by the employee.
- (ii) For all others, *i.e.*, those salaried taxpayers not in employment of the Central Government and the State Government, the valuation of perquisite in respect of accommodation would be at prescribed rates, as discussed below:

(a) Where the accommodation provided to the employee is owned by the employer:

<i>Sl No .</i>	<i>Cities having population as per the 2001 census</i>	<i>Perquisite</i>
1	Exceeds 25 lakh	15% of salary
2	Exceeds 10 lakhs but does not exceed 25 lakhs	10% of salary
3	For other places	7.5 % of salary

(b) Where the accommodation so provided is taken on lease/ rent by the employer:

The prescribed rate is 15% of the salary or the actual amount of lease rental payable by the employer, whichever is lower, as reduced by any amount of rent paid by the employee. Meaning of 'Salary 'for the purpose of calculation of perquisite in respect of Residential Accommodation :

- a. Basic Salary;
- b. Dearness Allowance, if terms of employment so provide ;
- c. Bonus ;
- d. Commission ;

- e. Fees ;
- f. All other taxable allowances (excluding the portion not taxable ); and
- g. Any monetary payment which is chargeable to tax (by whatever name called).

Further, Salary should be calculated on 'accrual' basis. Advance salary shall not be taken into consideration for this purpose. Salary from all employers shall be taken into consideration in respect of the period during which an accommodation is provided. Where on account of the transfer of an employee from one place to another, he is provided with accommodation at the new place of posting while retaining the accommodation at the other place, the value of perquisite shall be determined with reference to only one such accommodation which has the lower value for a period not exceeding 90 days and thereafter the value of perquisite shall be charged for both such accommodation.

B Valuation of the perquisite of furnished accommodation, the value of perquisite as determined by the above method (in A) shall be increased by-

- (i) 10% of the cost of furniture, appliances and equipments, or
- (ii) where the furniture, appliances and equipments have been taken on hire, by the amount of actual hire charges payable as reduced by any charges paid by the employee himself.

It is added that where the accommodation is provided by the Central Government or any State Government to an employee who is serving on deputation with anybody or undertaking under the control of such Government,-

- (i) the employer of such an employee shall be deemed to be that body or undertaking where the employee is serving on deputation; and
- (ii) the value of perquisite of such an accommodation shall be the amount calculated in accordance with Table in (ii)(a) above, as if the accommodation is owned by the employer.

**C. Furnished Accommodation in a Hotel:** The value of perquisite shall be determined on the basis of lower of the following two:

1. 24% of salary paid or payable in respect of period during which the accommodation is provided.
2. Actual charges paid or payable by the employer to such hotel.

for the period during which such accommodation is provided as reduced by any rent actually paid or payable by the employee.

However, nothing in C shall be taxable if following two conditions are satisfied :

1. The hotel accommodation is provided for total period not exceeding in aggregate 15 days in a previous year.
2. Such accommodation is provided on an employee's transfer from one place to another place.

It may be clarified that while services provided as an integral part of the accommodation, need not be valued separately as perquisite, any other services over and above that for which the employer makes payment or reimburses the employee shall be valued as a perquisite as per the residual clause. In other words, composite tariff for accommodation will be valued as per the Rules and any other charges for other facilities provided by the hotel will be separately valued under the residual clause.

**D.** If on account of an employee's transfer from one place to another, the employee is provided with accommodation at the new place of posting while retaining the accommodation at the other place, the

value of perquisite shall be determined with reference to only one such accommodation which has the lower value as per the table prescribed in Rule 3 of the Rules, for a period up to 90 days. However, after that the value of perquisite shall be charged for both accommodations as prescribed.

**E.** However, the value of any accommodation provided to an employee working at a mining site or an on-shore oil exploration site or a project execution site or a dam site or a power generation site or an off-shore site will not be treated as a perquisite if:

- (i) such accommodation should either be located in a "remote area" or
- (ii) where it is not located in a "remote area", the accommodation should be of a temporary nature having plinth area of not more than 800 square feet and should not be located within 8 kilometers of the local limits of any municipality or cantonment board.

A project execution site here means a site of project up to the stage of its commissioning. A "remote area" means an area located at least 40 kilometers away from a town having a population not exceeding 20,000 as per the latest published all-India census.

**II Personal attendants etc.:** The value of free service of all personal attendants including a sweeper, gardener and a watchman is to be taken at actual cost to the employer. Where the attendant is provided at the residence of the employee, full cost will be taxed as perquisite in the hands of the employee irrespective of the degree of personal service rendered to him. Any amount paid by the employee for such facilities or services shall be reduced from the above amount.

**III Gas, electricity & water:** Value of perquisite shall be determined at the amount paid or payable by the employer as reduced by the amount recovered if any, from the employee. It is taxable in the hands of all employees (whether specified or not) provided that the Water supply or electric connection is in the name of the employee and expenses are reimbursed by the employer. If, however, the Water supply or electric connection is in the name of the employer and the expenses are borne by the employer, perquisite is taxable only in the hands of specified employees.

Meaning of 'Specified Employee' :

1. Director Employee.
2. An employee having substantial interest (Beneficial owner of equity shares carrying 20% or more voting power).
3. An employee whose income chargeable under the head 'Salaries' (exclusive of the value of all benefits or amenities not provided by way of monetary payments) exceeds Rs.50,000/-.

Where the supply is made from the employer's own resources, the manufacturing cost per unit incurred by the employer would be taken for the valuation of perquisite. Any amount paid by the employee for such facilities or services shall be reduced from the above amount.

**IV Free or concessional education:** Perquisite on account of free or concessional education shall be valued in a manner assuming that such expenses are borne by the employee, and would cover cases where an employer is running, maintaining or directly or indirectly financing the educational institution. Any amount paid by the employee for such facilities or services shall be reduced from the above amount. However, where such educational institution itself is maintained and owned by the employer or where such free educational facilities are provided in any institution by reason of his being in employment of that employer, the value of the perquisite to the employee shall be determined with reference to the cost of such education in a similar institution in or near the locality if the cost of such education or such benefit per child exceeds Rs.1000/- p.m.

**V Interest free or concessional loans:** It is common practice, particularly in financial institutions, to



provide interest free or concessional loans to employees or any member of his household. The value of perquisite arising from such loans would be the excess of interest payable at prescribed interest rate over interest, if any, actually paid by the employee or any member of his household. The prescribed interest rate would now be the rate charged per annum by the State Bank of India as on the 1st day of the relevant financial year in respect of loans of same type and for the same purpose advanced by it to the general public. Perquisite value would be calculated on the basis of the maximum outstanding monthly balance method. For valuing perquisites under this rule, any other method of calculation and adjustment otherwise adopted by the employer shall not be relevant.

However, small loans up to Rs. 20,000/- in the aggregate are exempt. Loans for medical treatment specified in Rule 3A are also exempt, provided the amount of loan for medical reimbursement is not reimbursed under any medical insurance scheme. Where any medical insurance reimbursement is received, the perquisite value at the prescribed rate shall be charged from the date of reimbursement on the amount reimbursed, but not repaid against the outstanding loan taken specifically for this purpose.

**VI Use of assets:** It is common practice for an asset owned by the employer to be used by the employee or any member of his household. This perquisite is to be charged at the rate of 10% of the original cost of the asset as reduced by any charges recovered from the employee for such use. However, the use of Computers and Laptops would not give rise to any perquisite.

**VII Transfer of assets:** Often an employee or member of his household benefits from the transfer of movable asset (not being shares or securities) at no cost or at a cost less than its market value from the employer. The difference between the original cost of the movable asset (not being shares or securities) and the sum, if any, paid by the employee, shall be taken as the value of perquisite. In case of a movable asset, which has already been put to use, the original cost shall be reduced by a sum of 10% of such original cost for every completed year of use of the asset. Owing to a higher degree of obsolescence, in case of computers and electronic gadgets, however, the value of perquisite shall be worked out by reducing 50% of the actual cost by the reducing balance method for each completed year of use. Electronic gadgets in this case means data storage and handling devices like computer, digital diaries and printers. They do not include household appliance (i.e. white goods) like washing machines, microwave ovens, mixers, hot plates, ovens etc. Similarly, in case of cars, the value of perquisite shall be worked out by reducing 20% of its actual cost by the reducing balance method for each completed year of use.

**VIII Membership fees and Annual Fees Credit Card:** Any membership fees and annual fees incurred by the employee (or any member of his household), which is charged to credit card (including any add-on card) is taxable on the following basis:

Amount of expenditure incurred by the employer		XXX
Less : Expenditure on use for official purposes	XXX	
Less : Amount, if any, recovered from the employee	XXX	XXX
Amount taxable as non- monetary perquisite		XXX

#### **IX Club Expenditure:**

Any annual or periodical fees, on Club facility used by the employee (or any member of his household), which is paid or reimbursed by the employer is taxable on the following basis:

Amount of expenditure incurred by the employer		XXX
Less : Expenditure on use for official purposes		XXX
Less : Amount, if any, recovered from the employee	XXX	XXX
Amount taxable as non- monetary perquisite		XXX

Note: (1) Health club, sport facilities etc. provided uniformly to all classes of employee by the employer at

the employer's premises and expenditure incurred on them are exempt. (2) The initial one-time deposits or fees for corporate or institutional membership, where benefit does not remain with a particular employee after cessation of employment are exempt. Initial fees / deposits, in such case, is not included.

### **IXA Value of Subsidized / Free Lunch provided by employer to an employee:**

Value of taxable perquisite is calculated as under:

Expenditure incurred by the employer on the value of food /non-alcoholic including paid vouchers which are not transferable and usable only at eating joints	XXX
Less: Fixed value of a sum of Rs. 50/- per meal	XXX
Less: Amount recovered from the employee	XXX XXX
Balance amount is the taxable non- monetary perquisites on value of food provided to the employees	XXX

Note : Exemption is given in following situations :

1. Tea / snacks provided in working hours.
2. Food & non-alcoholic beverages provided in working hours in remote area or in an offshore installation.

### **X Holiday Facility maintained by employer:**

If a Holiday facility is maintained by the employer and is available uniformly to all employees, the value of such benefit would be exempted.

#### **5.2.2A.2 Monetary perquisites:**

### **XI Vehicle Maintenance reimbursement:**

- (a) Use of any vehicle provided by the employer to an employee for journey by him from his residence to office or from office to his residence shall not be chargeable to tax.
- (b) Where the car is owned by the employee or employer and maintenance & running expenses including driver salary, are met by the employer and if the car is used wholly for official purposes, no value shall be taken as perquisite provided :
  - i. The employer has maintained complete details of the journey undertaken for official purposes;
  - ii. The employer gives a certificate that the expenditure was incurred wholly for official duties.

Section 10(14) includes only those allowances which are not in the nature of perquisite within the meaning of section 17(2). Vehicle maintenance reimbursement falls within the purview of section 17(2). Hence, this exemption is not available to the employees claiming vehicle reimbursement for official purposes. Conveyance allowance to the extent of Rs 800/- p.m. or Rs. 1600 p.m (for a blind person) is allowable to all employees other than those claiming Vehicle reimbursement to meet the expenditure for the purpose of commuting between place of residence and place of office.

### **XII House Cleaning reimbursement:**

The value of benefit to the employee (or any member of the household), shall be the actual cost to the employer as reduced by the amount if any recovered from the employee. If a domestic servant is engaged by the employee, the perquisite is taxable in the hands of all employees (Whether specified or not). If a domestic servant is engaged by the employer, the perquisite is taxable in the hands of only specified

employees. If Domestic Servant allowance is given to the employee, it is chargeable to tax as perquisite even if the allowance is used for engaging a domestic servant.

### **XIII Book Grant reimbursement:**

If actual bills are provided it forms nature of reimbursement which is not taxable if it can be proved that acquisition of books is necessary for the purpose of the business.

### **XIV Staff Furnishing Scheme:**

It is a business expenditure if it can be proved that incurring such expense is necessary for the purpose of the business.

### **XV Brief Case reimbursement:**

It is a business expenditure if it can be proved that incurring such expense is necessary for the purpose of the business.

### **XVI Entertainment allowance:**

Any entertainment allowances paid to non-government employees are taxable.

### **XVII Gifts / Awards:**

If made in cash or convertible into money (like gift cheques), they are taxable as perquisites. If made in kind up to Rs. 5,000 in aggregate per annum would be exempt, beyond which it would be taxable.

### **XVIII Transfer Grant Allowance:**

In this connection it is to be noted that as per section 10(14) read with rule 2BB any allowance granted to meet the cost of travel on tour or on transfer includes any sum paid in connection with transfer, packing and transportation of personal effects on such transfer shall be exempt. Also any allowance, whether, granted for the period of journey in connection with transfer, to meet the ordinary daily charges incurred by an employee on account of absence from his normal place of duty shall be exempt.

### **XIX Holiday Expenditure reimbursement:**

It is not taxable. It is an allowable expenditure u/s 37 provided the holiday (picnic) is organized by the employer. However, any Expenditure paid or reimbursed by the employer for any holiday (one day picnic) availed or by the employee or any member or his household is to be considered as taxable perquisite.

### **XX Leave Travel Concession (LTC):**

The following are the important points, to be taken into consideration, for claiming exemption u/s 10(5) of the Act, read with Rule 2B of the Rules:

1. Definition - Value of LTC received by or due to an individual from his present or previous employer, as the case may be, for himself and his family in connection with his proceeding on leave to any place in India or to any place in India after retirement or termination from/of service. The exemption shall be available either if the employee is travelling alone or accompanying his family. But, exemption shall not be available if the family members are travelling separately without the employee who is not on leave.
2. Number of Trips - The exemption shall be available in respect of 2 journeys performed in the block of 4 calendar years.
  - On declaration basis - Without performing any journey and incurring expenses thereon, no

exemption can be claimed.

- On Non-declaration basis - The quantum of exemption will be subject to the following maximum limits for journeys performed on or after 1-10-1997:

<i>Sl. No</i>	<i>Journey Performed by</i>	<i>Exemption Limit</i>
1	Air	Air Economy fare of the national carrier (Air India) by the shortest route to the place of destination
2	Places connected by rail and journey performed by any mode other than by air.	First Class Air conditioned rail fare by the shortest route to the place of destination
3	Place of origin and destination or part thereof not connected by rail.	(a) Where public transport system exists, first class or deluxe class fare on such transport by the shortest route to the place of destination.  (b) Where no public transport system exists, first class A/C rail fare, for the distance of the journey by the shortest route, as if the journey has been performed by rail

- This exemption is limited to the actual expenses incurred on the journey which in turn is strictly limited to expenses on air fare, rail fare and bus fare only. No other expenses like local conveyance, sight-seeing expense etc., shall qualify for exemption.
- Where the journey is performed in a circuitous route, the exemption is limited to what is admissible by the shortest route. Likewise, where the journey is performed in a circular form touching different places, the exemption is limited to what is admissible for the journey from the place of origin to the farthest point reached in India, by the shortest route.
- Restriction on children - The exemption will not be available to more than 2 surviving children of an individual born after 1-10-1998. This restriction shall not apply in respect of children born before 1-10-1998 and also in case of multiple births after one child. It may be noted that section 2 (15B) of the Act defines a child as includes a step child and an adopted child of the individual.
- Definition of Family - As per the provisions of the Rules, family means:
  - Spouse and children of the individual.
  - Parents, brothers and sisters who are wholly or mainly dependent on the individual.
- Foreign Travel - As per the provisions of the Rules, exemption is not allowable in case of travel abroad.
- Obligation of the employer -the employer has to satisfy the obligation that leave travel (fare) concession is not taxable in view of section 10(5), the employer is not only required to be satisfied about the ingredients of the said clause but also to keep and preserve evidence in support thereof.

Some important points to be considered are as under:

1. It is uniform for all employees
2. Where an employee does not avail LTC, either one or on both the occasions during the block of 4 calendar years, the value of LTC first availed during the first calendar year of the immediately succeeding block shall be eligible for exemption in lieu of exemption not availed during the preceding block Only one trip can be carried forward to be availed in the immediately succeeding block.
3. Quantum of Exemption - The basic rule is that quantum of exemption will be limited to the actual expense incurred on the journey.

**XXI Medical Reimbursement by the employer** exceeding Rs. 15,000/- p.a. u/s 17(2)(v) is to be taken as perquisite.

It is further clarified that the rule position regarding valuation of perquisites are given at Section 17(2) of the Act and at Rule 3 of the Rules. The deductors may look into the above provisions carefully before they determine the perquisite value for deduction purposes.

It is pertinent to mention that benefits specifically exempt u/s 10(13A), 10(5), 10(14), 17 etc. of the Act would continue to be exempt. These include benefits like travel on tour and transfer, leave travel, daily allowance to meet tour expenses as prescribed, medical facilities subject to conditions.

### **5.2.3 'Profits in lieu of salary' shall include**

- I. the amount of any compensation due to or received by an assessee from his employer or former employer at or in connection with the termination of his employment or the modification of the terms and conditions relating thereto;
- II. any payment (other than any payment referred to in Section 10 of (10), (10A), (10B), (11), (12) (13) (13A) due to or received by an assessee from an employer or a former employer or from a provident or other fund, to the extent to which it does not consist of contributions by the assessee or [interest on such contributions or any sum received under a Keyman insurance policy including the sum allocated by way of bonus on such policy.

"Keyman insurance policy" shall have the same meaning as assigned to it in section 10(10D);]

- III. any amount due to or received, whether in lump sum or otherwise, by any assessee from any person—
  - (A) before his joining any employment with that person; or
  - (B) after cessation of his employment with that person.

### **5.3 Incomes not included under the Head "Salaries"(Exemptions)**

Any income falling within any of the following clauses shall not be included in computing the income from salaries for the purpose of Section 192 of the Act :-

(1) The value of any travel concession or assistance received by or due to an employee from his employer or former employer for himself and his family, in connection with his proceeding (a) on leave to any place in India or (b) on retirement from service, or, after termination of service to any place in India is exempt under Section 10(5) subject, however, to the conditions prescribed in Rule 2B of the Rules.

For the purpose of this clause, "family" in relation to an individual means:

- (i) the spouse and children of the individual; and

- (ii) the parents, brothers and sisters of the individual or any of them, wholly or mainly dependent on the individual.

It may also be noted that the amount exempt under this clause shall in no case exceed the amount of expenses actually incurred for the purpose of such travel.

(2) Death-*cum*-retirement gratuity or any other gratuity which is exempt to the extent specified from inclusion in computing the total income under Section 10(10). Any death-*cum*-retirement gratuity received under the revised Pension Rules of the Central Government or, as the case may be, the Central Civil Services (Pension) Rules, 1972, or under any similar scheme applicable to the members of the civil services of the Union or holders of posts connected with defence or of civil posts under the Union (such members or holders being persons not governed by the said Rules) or to the members of the all-India services or to the members of the civil services of a State or holders of civil posts under a State or to the employees of a local authority or any payment of retiring gratuity received under the Pension Code or Regulations applicable to the members of the defence service. Gratuity received in cases other than above on retirement, termination etc. is exempt up to the limit as prescribed by the Board. Presently the limit is Rs. 10 lakhs w.e.f. 24-5-2010 [Notification no. 43/2010 S.O. 1414(E) F.No. 200/33/2009-ITA-I, dated 11th, June 2010].

(3) Any payment in commutation of pension received under the Civil Pension(Commutation) Rules of the Central Government or under any similar scheme applicable to the members of the civil services of the Union, or holders of civil posts/posts connected with defence, under the Union, or civil posts under a State, or to the members of the All India Services/Defence Services, or, to the employees of a local authority or a corporation established by a Central, State or Provincial Act, is exempt under Section 10(10A)(i). As regards payments in commutation of pension received under any scheme of any other employer, exemption will be governed by the provisions of section 10(10A)(ii). Also, any payment in commutation of pension from a fund referred to in Section 10(23AAB) is exempt under Section 10(10A)(iii).

(4) Any payment received by an employee of the Central Government or a State Government, as cash-equivalent of the leave salary in respect of the period of earned leave at his credit at the time of his retirement, whether on superannuation or otherwise, is exempt under Section 10(10AA)(i). In the case of other employees, this exemption will be determined with reference to the leave to their credit at the time of retirement on superannuation, or otherwise, subject to a maximum of ten months' leave. This exemption will be further limited to the maximum amount specified by the Government of India Notification No. S.O.588(E), dated 31-5-2002 at Rs. 3,00,000/- in relation to such employees who retire, whether on superannuation or otherwise, after 1-4-1998.

(5) Under Section 10(10B), the retrenchment compensation received by a workman is exempt from income-tax subject to certain limits. The maximum amount of retrenchment compensation exempt is the sum calculated on the basis provided in section 25F(b) of the Industrial Disputes Act, 1947 or any amount not less than Rs. 50,000/- as the Central Government may by notification specify in the official gazette, whichever is less. These limits shall not apply in the case where the compensation is paid under any scheme which is approved in this behalf by the Central Government, having regard to the need for extending special protection to the workmen in the undertaking to which the scheme applies and other relevant circumstances. The maximum limit of such payment is Rs. 5,00,000/- where retrenchment is on or after 1-1-1997.

(6) Under Section 10(10C), any payment received or receivable (even if received in instalments) by an employee of the following bodies at the time of his voluntary retirement or termination of his service, in accordance with any scheme or schemes of voluntary retirement or in the case of public sector company, a scheme of voluntary separation, is exempted from income-tax to the extent that such amount does not exceed Rs. 5,00,000/-:

- (a) A public sector company;
- (b) Any other company;

- (c) An Authority established under a Central, State or Provincial Act;
- (d) A Local Authority;
- (e) A Cooperative Society;
- (f) A university established or incorporated or under a Central, State or Provincial Act, or, an Institution declared to be a University under section 3 of the University Grants Commission Act, 1956;
- (g) Any Indian Institute of Technology within the meaning of Section 3(g) of the Institute of Technology Act, 1961;
- (h) Such Institute of Management as the Central Government may by notification in the Official Gazette, specify in this behalf.

The exemption of amount received under VRS has been extended to employees of the Central Government and State Government and employees of notified institutions having importance throughout India or any State or States. It may also be noted that where this exemption has been allowed to any employee for any assessment year, it shall not be allowed to him for any other assessment year.

(7) Any sum received under a Life Insurance Policy (Section 10(10D), including the sum allocated by way of bonus on such policy other than:

- (i) any sum received under section 80DD(3) or section 80DDA(3) or,
- (ii) any sum received under Keyman insurance policy or,
- (iii) any sum received under an insurance policy issued on or after 1-4-2003, but on or before 31-3-2012, in respect of which the premium payable for any of the years during the term of the policy exceeds 20 per cent of the actual capital sum assured. However, any sum received under such policy on the death of a person would still be exempt.

(8) Any payment from a Provident Fund [section 10(11)] to which the Provident Funds Act, 1925 ( 19 of 1925), applies or from any other provident fund set up by the Central Government and notified by it in this behalf in the Official Gazette.

(9) Under Section 10(13A) of Act any special allowance specifically granted to an assessee by his employer to meet expenditure incurred on payment of rent (by whatever name called) in respect of residential accommodation occupied by the assessee is exempt from Income-tax to the extent as may be prescribed, having regard to the area or place in which such accommodation is situated and other relevant considerations. According to Rule 2A of the Rules, the quantum of exemption allowable on account of grant of special allowance to meet expenditure on payment of rent shall be:

- (a) The actual amount of such allowance received by the assessee in respect of the relevant period; or
- (b) The actual expenditure incurred in payment of rent in excess of 1/10 of the salary due for the relevant period; or
- (c) Where such accommodation is situated in Bombay, Calcutta, Delhi or Madras, 50% of the salary due to the employee for the relevant period; or
- (d) Where such accommodation is situated in any other places, 40% of the salary due to the employee for the relevant period, whichever is the least.

For this purpose, "Salary" includes dearness allowance, if the terms of employment so provide, but excludes all other allowances and perquisites.

It has to be noted that only the expenditure actually incurred on payment of rent in respect of residential accommodation occupied by the assessee subject to the limits laid down in Rule 2A, qualifies for exemption from income-tax. Thus, house rent allowance granted to an employee who is residing in a house/flat owned by him is not exempt from income-tax. The disbursing authorities should satisfy themselves in this regard by insisting on production of evidence of actual payment of rent before excluding the House Rent Allowance or any portion thereof from the total income of the employee.

Though incurring actual expenditure on payment of rent is a pre-requisite for claiming deduction under section 10(13A), it has been decided as an administrative measure that salaried employees drawing house rent allowance up to Rs. 3000/- per month will be exempted from production of rent receipt. It may, however, be noted that this concession is only for the purpose of tax-deduction at source, and, in the regular assessment of the employee, the Assessing Officer will be free to make such enquiry as he deems fit for the purpose of satisfying himself that the employee has incurred actual expenditure on payment of rent.

Further if annual rent paid by the employee exceeds Rs. 2,00,000 per annum, it is mandatory for the employee to report PAN of the landlord to the employer. In case the landlord does not have a PAN, a declaration to this effect from the landlord along with the name and address of the landlord should be filed by the employee.

(10) Section 10(14) provides for exemption of the following allowances :-

- (i) Any special allowance or benefit granted to an employee to meet the expenses incurred in the performance of his duties as prescribed under Rule 2BB subject to the extent to which such expenses are actually incurred for that purpose.
- (ii) Any allowance granted to an employee either to meet his personal expenses at the place of his posting or at the place he ordinarily resides or to compensate him for the increased cost of living, which may be prescribed and to the extent as may be prescribed.

However, the allowance referred to in (ii) above should not be in the nature of a personal allowance granted to the assessee to remunerate or compensate him for performing duties of a special nature relating to his office or employment unless such allowance is related to his place of posting or residence.

The CBDT has prescribed guidelines for the purpose of Section 10(14) (i) / (ii) *vide* notification No. SO617(E), dated 7th July, 1995 (F. No. 142/9/95-TPL) which has been amended *vide* notification SO No. 403(E), dt. 24-4-2000 (F. No. 142/34/99-TPL). The transport allowance granted to an employee to meet his expenditure for the purpose of commuting between the place of his residence and the place of duty is exempt to the extent of Rs.800 per month *vide* notification S.O. No. 395(E), dated 13-5-1998.

(11) Under Section 10(15)(iv)(i) of the Act, interest payable by the Government on deposits made by an employee of the Central Government or a State Government or a public sector company out of his retirement benefits, in accordance with such scheme framed in this behalf by the Central Government and notified in the Official Gazette is exempt from income-tax. By notification No. F. 2/14/89-NS-II, dated 7-6-1989, as amended by notification No. F. 2/14/89-NS-II, dated 12-10-1989, the Central Government has notified a scheme called Deposit Scheme for Retiring Government Employees, 1989 for the purpose of the said clause.

(12) Any scholarship granted to meet the cost of education is not to be included in total income as per of section 10(16) of the Act.

(13) Section 10(18) provides for exemption of any income by way of pension received by an individual who has been in the service of the Central Government or State Government and has been awarded "Param Vir Chakra" or "Maha Vir Chakra" or "Vir Chakra" or such other gallantry award as may be specifically notified by the Central Government or family pension received by any member of the family of such individual [Notifications No. S.O. 1948(E) dated 24-11-2000 and 81(E), dated 29-1-2001, which



are enclosed as per Annexure]. "Family" for this purpose shall have the meaning assigned to it in Section 10(5) of the Act.

DDO may not deduct any tax in the case of recipients of such awards after satisfying himself about the veracity of the claim.

(14) Under Section 17 of the Act, exemption from tax will also be available in respect of:-

- (a) the value of any medical treatment provided to an employee or any member of his family, in any hospital maintained by the employer;
- (b) any sum paid by the employer in respect of any expenditure actually incurred by the employee on his medical treatment or of any member of his family:
  - (i) in any hospital maintained by the Government or any local authority or any other hospital approved by the Government for the purposes of medical treatment of its employees;
  - (ii) in respect of the prescribed diseases or ailments as provided in Rule 3A(2) of the Rules in any hospital approved by the Chief Commissioner having regard to the prescribed guidelines as provided in Rule 3(A)(I) of the Rules.
- (c) premium paid by the employer in respect of medical insurance taken for his employees (under any scheme approved by the Central Government or Insurance Regulatory and Development Authority) or reimbursement of insurance premium to the employees who take medical insurance for themselves or for their family members (under any scheme approved by the Central Government or Insurance Regulatory and Development Authority);
- (d) reimbursement, by the employer, of the amount spent by an employee in obtaining medical treatment for himself or any member of his family from any doctor, not exceeding in the aggregate Rs. 15,000/- in an year.
- (e) As regards medical treatment abroad, the actual expenditure on stay and treatment abroad of the employee or any member of his family, or, on stay abroad of one attendant who accompanies the patient, in connection with such treatment, will be excluded from perquisites to the extent permitted by the Reserve Bank of India. It may be noted that the expenditure incurred on travel abroad by the patient/attendant, shall be excluded from perquisites only if the employee's gross total income, as computed before including the said expenditure, does not exceed Rs. 2 lakhs.

For the purpose of availing exemption on expenditure incurred on medical treatment, "hospital" includes a dispensary or clinic or nursing home, and "family" in relation to an individual means the spouse and children of the individual. Family also includes parents, brothers and sisters of the individual if they are wholly or mainly dependent on the individual.

## **5.4 Deductions u/s 16 of the Act from the Income from Salaries**

### **5.4.1 Entertainment Allowance [Section 16(ii)]:**

A deduction is also allowed under section 16(ii) in respect of any allowance in the nature of an entertainment allowance specifically granted by an employer to the assessee, who is in receipt of a salary from the Government, a sum equal to one-fifth of his salary (exclusive of any allowance, benefit or other perquisite) or five thousand rupees whichever is less. No deduction on account of entertainment allowance is available to non-government employees.

### **5.4.2 Tax on Employment [Section 16(iii)]:**

The tax on employment (Professional Tax) within the meaning of Article 276(2) of the Constitution of India, leviable by or under any law, shall also be allowed as a deduction in computing the income under

the head "Salaries".

It may be clarified that "Standard Deduction" from gross salary income, which was being allowed up to financial year 2004-05 is not allowable from financial year 2005-06 onwards.

### **5.5 Deductions under Chapter VI-A of the Act**

In computing the taxable income of the employee, the following deductions under Chapter VI-A of the Act are to be allowed from his gross total income:

**5.5.1** Deduction in respect of Life insurance premia, deferred annuity, contributions to provident fund, subscription to certain equity shares or debentures, etc. (section 80C)

Section 80C, entitles an employee to deductions for the whole of amounts paid or deposited in the current financial year in the following schemes, subject to a limit of Rs. 1,00,000/-:

- (1) Payment of insurance premium to effect or to keep in force an insurance on the life of the individual, the spouse or any child of the individual.
- (2) Any payment made to effect or to keep in force a contract for a deferred annuity, not being an annuity plan as is referred to in item (7) herein below on the life of the individual, the spouse or any child of the individual, provided that such contract does not contain a provision for the exercise by the insured of an option to receive a cash payment in lieu of the payment of the annuity;
- (3) Any sum deducted from the salary payable by, or, on behalf of the Government to any individual, being a sum deducted in accordance with the conditions of his service for the purpose of securing to him a deferred annuity or making provision for his spouse or children, in so far as the sum deducted does not exceed 1/5th of the salary;
- (4) Any contribution made :
  - (a) by an individual to any Provident Fund to which the Provident Fund Act, 1925 applies;
  - (b) to any provident fund set up by the Central Government, and notified by it in this behalf in the Official Gazette, where such contribution is to an account standing in the name of an individual, or spouse or children;  
  
[The Central Government has since notified Public Provident Fund vide Notification S.O. No. 1559(E), dated 3-11-2005]
  - (c) by an employee to a Recognized Provident Fund;
  - (d) by an employee to an approved superannuation fund;

It may be noted that "contribution" to any Fund shall not include any sums in repayment of loan;

(5) Any subscription :-

- (a) to any such security of the Central Government or any such deposit scheme as the Central Government may, by notification in the Official Gazette, specify in this behalf;
- (b) to any such saving certificates as defined under section 2(c) of the Government Saving Certificate Act, 1959 as the Government may, by notification in the Official Gazette, specify in this behalf.

[Central Government has since notified National Saving Certificate (VIIIth Issue) vide Notification S.O. No. 1560(E), dated 3-11-2005 and National Saving Certificate (IXth Issue) vide Notification S.O. No. (E), dated 29-11-2011 F. No. I-13/2011-NS-II]

- (6) Any sum paid as contribution in the case of an individual, for himself, spouse or any child,
- a. for participation in the Unit Linked Insurance Plan, 1971 of the Unit Trust of India;
  - b. for participation in any unit-linked insurance plan of the LIC Mutual Fund referred to section 10 (23D) and as notified by the Central Government.

[The Central Government has since notified Unit Linked Insurance Plan (formerly known as Dhanraksha, 1989) of LIC Mutual Fund vide Notification S.O. No. 1561(E), dated 3-11-2005.]

- (7) Any subscription made to effect or keep in force a contract for such annuity plan of the Life Insurance Corporation or any other insurer as the Central Government may, by notification in the Official Gazette, specify;

[The Central Government has since notified New Jeevan Dhara, New Jeevan Dhara-I New Jeevan Akshay, New Jeevan, Akshay-I and New Jeevan Akshay-II *vide* Notification S.O. No. 1562(E), dated 3-11-2005 and Jeevan Akshay-III *vide* Notification S.O. No. 847(E), dated 1-6-2006]

- (8) Any subscription made to any units of any Mutual Fund, of section 10(23D), or from the Administrator or the specified company referred to in Unit Trust of India (Transfer of Undertaking & Repeal) Act, 2002 under any plan formulated in accordance with any scheme as the Central Government, may, by notification in the Official Gazette, specify in this behalf;

[The Central Government has since notified the Equity Linked Saving Scheme, 2005 for this purpose vide Notification S.O. No. 1563(E), dated 3-11-2005]

The investments made after 1-4-2006 in plans formulated in accordance with Equity Linked Saving Scheme, 1992 or Equity Linked Saving Scheme, 1998 shall also qualify for deduction under section 80C.

- (9) Any contribution made by an individual to any pension fund set up by any Mutual Fund referred to in section 10(23D), or, by the Administrator or the specified company referred to in Unit Trust of India (Transfer of Undertaking & Repeal) Act, 2002, as the Central Government may, by notification in the Official Gazette, specify in this behalf;

[The Central Government has since notified UTI-Retirement Benefit Pension Fund vide Notification S.O. No. 1564(E) dated 3-11-2005.]

- (10) Any subscription made to any such deposit scheme of, or, any contribution made to any such pension fund set up by, the National Housing Bank, as the Central Government may, by notification in the Official Gazette, specify in this behalf;

- (11) Any subscription made to any such deposit scheme, as the Central Government may, by notification in the Official Gazette, specify for the purpose of being floated by (a) public sector companies engaged in providing long-term finance for construction or purchase of houses in India for residential purposes, or, (b) any authority constituted in India by, or, under any law, enacted either for the purpose of dealing with and satisfying the need for housing accommodation or for the purpose of planning, development or improvement of cities, towns and villages, or for both.

[The Central Government has since notified the Public Deposit Scheme of HUDCO vide Notification S.O. No. 37(E), dated 11-1-2007, for the purposes of Section 80C(2)(xvi)(a)].

- (12) Any sums paid by an assessee for the purpose of purchase or construction of a residential house property, the income from which is chargeable to tax under the head "Income from house property" (or which would, if it has not been used for assessee's own residence, have been chargeable to tax under that head) where such payments are made towards or by way of any instalment or part payment of the amount due under any self-financing or other scheme of any Development Authority, Housing Board etc.

The deduction will also be allowable in respect of re-payment of loans borrowed by an assessee from the Government, or any bank or Life Insurance Corporation, or National Housing Bank, or certain other categories of institutions engaged in the business of providing long term finance for construction or purchase of houses in India. Any repayment of loan borrowed from the employer will also be covered, if the employer happens to be a public company, or a public sector company, or a university established by law, or a college affiliated to such university, or a local authority, or a cooperative society, or an authority, or a board, or a corporation, or any other body established under a Central or State Act.

The stamp duty, registration fee and other expenses incurred for the purpose of transfer shall also be covered. Payment towards the cost of house property, however, will not include, admission fee or cost of share or initial deposit or the cost of any addition or alteration to, or, renovation or repair of the house property which is carried out after the issue of the completion certificate by competent authority, or after the occupation of the house by the assessee or after it has been let out. Payments towards any expenditure in respect of which the deduction is allowable under the provisions of section 24 of the Act will also not be included in payments towards the cost of purchase or construction of a house property.

Where the house property in respect of which deduction has been allowed under these provisions is transferred by the tax-payer at any time before the expiry of five years from the end of the financial year in which possession of such property is obtained by him or he receives back, by way of refund or otherwise, any sum specified in section 80C(2)(xviii), no deduction under these provisions shall be allowed in respect of such sums paid in such previous year in which the transfer is made and the aggregate amount of deductions of income so allowed in the earlier years shall be added to the total income of the assessee of such previous year and shall be liable to tax accordingly.

(13) Tuition fees, whether at the time of admission or thereafter, paid to any university, college, school or other educational institution situated in India, for the purpose of full-time education of any two children of the employee.

Full-time education includes any educational course offered by any university, college, school or other educational institution to a student who is enrolled full-time for the said course. It is also clarified that full-time education includes play-school activities, pre-nursery and nursery classes.

It is clarified that the amount allowable as tuition fees shall include any payment of fee to any university, college, school or other educational institution in India except the amount representing payment in the nature of development fees or donation or capitation fees or payment of similar nature.

(14) Subscription to equity shares or debentures forming part of any eligible issue of capital made by a public company, which is approved by the Board or by any public finance institution.

(15) Subscription to any units of any mutual fund referred to in clause (23D) of Section 10 and approved by the Board, if the amount of subscription to such units is subscribed only in eligible issue of capital of any company.

(16) Investment as a term deposit for a fixed period of not less than five years with a scheduled bank, which is in accordance with a scheme framed and notified by the Central Government, in the Official Gazette for these purposes.

[The Central Government has since notified the Bank Term Deposit Scheme, 2006 for this purpose *vide* Notification S.O. No. 1220(E) dated 28-7-2006]

(17) Subscription to such bonds issued by the National Bank for Agriculture and Rural Development, as the Central Government may, by such notification in the Official Gazette, specify in this behalf.

(18) Any investment in an account under the Senior Citizens Savings Scheme Rules, 2004.

(19) Any investment as five year time deposit in an account under the Post Office Time Deposit Rules,

1981.

Section 80C(3) & 80C(3A) states that in case of Insurance Policy other than contract for a deferred annuity the amount of any premium or other payment made is restricted to:

Policy issued before 1st April 2012	20% of the actual capital sum assured
Policy issued on or after 1st April 2012	10% of the actual capital sum assured

From 1-4-2013 actual capital sum assured in relation to a life insurance policy means the minimum amount assured under the policy on happening of the insured event at any time during the term of the policy, not taking into account -

- i. the value of any premiums agreed to be returned, or
- ii. any benefit by way of bonus or otherwise over and above the sum actually assured which may be received under the policy by any person.

### 5.5.2 Deduction in respect of contribution to certain pension funds (Section 80CCC)

Section 80CCC allows an employee deduction of an amount paid or deposited out of his income chargeable to tax to effect or keep in force a contract for any annuity plan of Life Insurance Corporation of India or any other insurer for receiving pension from the Fund referred to in section 10(23AAB). However, the deduction shall exclude interest or bonus accrued or credited to the employee's account, if any and shall not exceed Rs. 1 lakh.

However, if any amount is standing to the credit of the employee in the fund referred above and deduction has been allowed as stated above and the employee or his nominee receives this amount together with the interest or bonus accrued or credited to this account due to the reason of :

- (i) Due to surrender annuity plan whether in whole or part
- (ii) Pension received from the annuity plan

then the amount so received during the Financial Years shall be the income to the employee or his nominee for that Financial Year and accordingly will be charged to tax.

Where any amount paid or deposited by the employee has been taken into account for the purposes of this section, a deduction with reference to such amount shall not be allowed under section 80C.

### 5.5.3 Deduction in respect of contribution to pension scheme of Central Government (Section 80CCD):

Section 80CCD allows an employee, being an individual employed by the Central Government or any other employer, on or after the 1-1-2004, a deduction of an amount paid or deposited out of his income chargeable to tax under a pension scheme as notified or as may be notified by the Central Government, *vide* Notification F. N. 5/7/2003- ECB&PR, dated 22-12-2003. However, the deduction shall not exceed an amount equal to 10% of his salary (includes Dearness Allowance but excludes all other allowance and perquisites).

Further where in the case of an employee receives any contribution in the said pension scheme from the Central Government or any other employer then the employee shall be allowed a deduction from his total income of the whole amount contributed by the Central Government or any other employer subject to limit of 10% of his salary of the previous year.

However, if any amount is standing to the credit of the employee in the pension scheme referred above and deduction has been allowed as stated above and the employee or his nominee receives this amount

together with the amount accrued thereon, due to the reason of

- (i) Closure or opting out of the pension scheme or
- (ii) Pension received from the annuity plan purchased and taken on such closure or opting out

then the amount so received during the FYs shall be the income of the employee or his nominee for that Financial Year and accordingly will be charged to tax.

Where any amount paid or deposited by the employee has been taken into account for the purposes of this section, a deduction with reference to such amount shall not be allowed under section 80C.

Further it has been specified that w.r.e.f 1-4-2009 any amount received by the employee from the new pension scheme shall be deemed not to have received in the previous year if such amount is used for purchasing an annuity plan in the previous year.

It is emphasized that as per the section 80CCE the aggregate amount of deduction under sections 80C, 80CCC and Section 80CCD(1) shall not exceed Rs. 1,00,000/-. However the contribution made by the Central Government or any other employee to a pension scheme u/s 80CCD(2) shall be excluded from the limit of Rs.1,00,000/- provided under this Section.

#### **5.5.4 Deduction in respect of subscription to Long Term Infrastructure Bonds:**

Section 80CCF has been withdrawn from FY 2012-13. Hence no deduction is allowable under this section for the current FY onwards.

#### **5.5.5 Deduction in respect of investment made under an equity savings savings (Section 80 CCG):**

Newly inserted Section 80CCG provides deduction w.e.f. assessment year 2013-14 in respect of investment made under notified equity saving scheme. The deduction under this section is available if following conditions are satisfied:

- (a) The assessee is a resident individual (may be ordinarily resident or not ordinarily resident)
- (b) His gross total income does not exceed Rs. 10 lakhs;
- (c) He has acquired listed shares in accordance with a notified scheme;
- (d) The assessee is a new retail investor as specified in the above notified scheme;
- (e) The investment is locked-in for a period of 3 years from the date of acquisition in accordance with the above scheme;
- (f) The assessee satisfies any other condition as may be prescribed.

*Amount of deduction* -The amount of deduction is at 50% of amount invested in equity shares. However, the amount of deduction under this provision cannot exceed Rs. 25,000. If any deduction is claimed by a taxpayer under this section in any year, he shall not be entitled to any deduction under this section for any subsequent year.

*Withdrawal of deduction* - If the assessee, after claiming the aforesaid deduction, fails to satisfy the above conditions, the deduction originally allowed shall be deemed to be the income of the assessee of the year in which default is committed.

A scheme named "Rajiv Gandhi Equity Savings Scheme (RGESS)" is being notified for the purpose of this deduction.

### 5.5.6 Deduction in respect of for health insurance premia paid, etc. (Section 80D)

Section 80D provides for deduction available for health insurance premia paid, etc. which is calculated as under:

Sl. No.	Persons for whom payment made	Nature of payment	Mode of payment	Allowable Deduction (in Rs.)
1	Employee or his family	<ul style="list-style-type: none"> <li>◆ the whole of the amount paid to effect or to keep in force an insurance on the health of the employee or his family or</li> <li>◆ any contribution made to the CGHS or</li> <li>◆ any payment on account of preventive health check-up of the employee or family, [restricted to Rs. 5000/-; cash payment allowed here]</li> </ul>	any mode other than cash	Aggregate allowable is Rs. 15,000/{For Senior Citizens it is Rs. 20000/-}.
2	Parent or Parents of employee	<ul style="list-style-type: none"> <li>◆ the whole of the amount paid to effect or keep in force an insurance on the health of the parent or parents of the employee or</li> <li>◆ any payment made on account of preventive health check-up of the parent or parents of the employee [restricted to Rs. 5000/-; cash payment allowed here]</li> </ul>	any mode other than cash	Aggregate allowable is Rs. 15,000/ than {For Senior cash Citizens it is Rs. 20000/-}

Here

- (i) "family" means the spouse and dependent children of the employee.
- (ii) Senior citizen" means an individual resident in India who is of the age of sixty years {For AY 2013-14 onwards] or more at any time during the relevant previous year.

The DDO must ensure that the medical insurance referred to above shall be in accordance with a scheme made in this behalf by-

- (a) the General Insurance Corporation of India formed under section 9 of the General Insurance Business (Nationalization) Act, 1972 (57 of 1972) and approved by the Central Government in this behalf; or
- (b) any other insurer and approved by the Insurance Regulatory and Development Authority established under sub-section (1) of section 3 of the Insurance Regulatory and Development Authority Act, 1999(41 of 1999).

### 5.5.7 Deductions in respect of expenditure on persons or dependants with disability

#### 5.5.7.1 Deductions in respect of maintenance including medical treatment of a dependent who is a person with disability (section 80DD):

Under section 80DD, where an employee, who is a resident in India, has, during the previous year-

- (a) incurred any expenditure for the medical treatment (including nursing), training and rehabilitation of a dependant, being a person with disability; or
- (b) paid or deposited any amount under a scheme framed in this behalf by the Life Insurance Corporation or any other insurer or the Administrator or the specified company subject to the conditions specified in this regard and approved by the Board in this behalf for the maintenance of a dependant, being a person with disability, the employee shall be allowed a deduction of a sum of fifty thousand rupees from his gross total income of that year.

However, where such dependant is a person with severe disability, an amount of one hundred thousand rupees shall be allowed as deduction subject to the specified conditions.

The deduction under (b) above shall be allowed only if the following conditions are fulfilled:-

- (i) the scheme referred to in (b) above provides for payment of annuity or lump sum amount for the benefit of a dependant, being a person with disability, in the event of the death of the individual in whose name subscription to the scheme has been made;
- (ii) the employee nominates either the dependant, being a person with disability, or any other person or a trust to receive the payment on his behalf, for the benefit of the dependant, being a person with disability.

However, if the dependant, being a person with disability, predeceases the employee, an amount equal to the amount paid or deposited under sub-para (b) above shall be deemed to be the income of the employee of the previous year in which such amount is received by the employee and shall accordingly be chargeable to tax as the income of that previous year.

#### **5.5.7.2 Deductions in respect of a person with disability (section 80U):**

Under section 80U, in computing the total income of an individual, being a resident, who, at any time during the previous year, is certified by the medical authority to be a person with disability, there shall be allowed a deduction of a sum of fifty thousand rupees. However, where such individual is a person with severe disability, a higher deduction of one lakh rupees shall be allowable.

DDOs should note that section 80DD deduction is in case of the dependent of the employee whereas section 80U deduction is in case of the employee himself. However under both the Sections the employee shall furnish to the DDO following:

1. A copy of the certificate issued by the medical authority as defined in Rule 11A(1) in the prescribed form as per Rule 11A(2) of the Rules. The DDO has to allow deduction only after seeing that the Certificate furnished is from the Medical Authority defined in this Rule and the same is in the form as mentioned therein.
2. Further In cases where the condition of disability is temporary and requires reassessment of its extent after a period stipulated in the aforesaid certificate, no deduction under this section shall be allowed for any subsequent period unless a new certificate is obtained from the medical authority as in 1 above and furnished before the DDO.
3. For the purposes of section 80DD and 80 U some of the terms defined are as under:-
  - (a) "Administrator" means the Administrator as referred to in clause (a) of section 2 of the Unit Trust of India (Transfer of Undertaking and Repeal) Act, 2002 (58 of 2002) ;
  - (b) "dependant" means—



- (i) in the case of an individual, the spouse, children, parents, brothers and sisters of the individual or any of them;
- (ii) in the case of a Hindu undivided family, a member of the Hindu undivided family, dependant wholly or mainly on such individual or Hindu undivided family for his support and maintenance, and who has not claimed any deduction under section 80U in computing his total income for the assessment year relating to the previous year;
- (c) "disability" shall have the meaning assigned to it in clause (i) of section 2 of the Persons with Disabilities (Equal Opportunities, Protection of Rights and Full Participation) Act, 1995 (1 of 1996) and includes "autism", "cerebral palsy" and "multiple disability" referred to in clauses (a), (c) and (h) of section 2 of the National Trust for Welfare of Persons with Autism, Cerebral Palsy, Mental Retardation and Multiple Disabilities Act, 1999 (44 of 1999);
- (d) "Life Insurance Corporation" shall have the same meaning as in clause (iii) of sub-section (8) of section 88;
- (e) "medical authority" means the medical authority as referred to in clause (p) of section 2 of the Persons with Disabilities (Equal Opportunities, Protection of Rights and Full Participation) Act, 1995 (1 of 1996) or such other medical authority as may, by notification, be specified by the Central Government for certifying "autism", "cerebral palsy", "multiple disabilities", "person with disability" and "severe disability" referred to in clauses (a), (c), (h), (j) and (o) of section 2 of the National Trust for Welfare of Persons with Autism, Cerebral Palsy, Mental Retardation and Multiple Disabilities Act, 1999 (44 of 1999);
- (f) "person with disability" means a person as referred to in clause (t) of section 2 of the Persons with Disabilities (Equal Opportunities, Protection of Rights and Full Participation) Act, 1995 (1 of 1996) or clause (j) of section 2 of the National Trust for Welfare of Persons with Autism, Cerebral Palsy, Mental Retardation and Multiple Disabilities Act, 1999 (44 of 1999);  
"person with severe disability" means—
  - (i) a person with eighty per cent or more of one or more disabilities, as referred to in sub-section (4) of section 56 of the Persons with Disabilities (Equal Opportunities, Protection of Rights and Full Participation) Act, 1995 (1 of 1996); or
  - (ii) a person with severe disability referred to in clause (o) of section 2 of the National Trust for Welfare of Persons with Autism, Cerebral Palsy, Mental Retardation and Multiple Disabilities Act, 1999 (44 of 1999);
- (h) "specified company" means a company as referred to in clause (h) of section 2 of the Unit Trust of India (Transfer of Undertaking and Repeal) Act, 2002 (58 of 2002).

#### **5.5.8. Deduction in respect of medical treatment, etc. (Section 80DDB):**

Section 80DDB allows a deduction in case of employee, who is resident in India, during the previous year, actually paid any amount for the medical treatment of such disease or ailment as may be specified in the rules HDD (1) (*see* Annexure) for himself or a dependant. The deduction allowed is equal to the amount actually paid or Rs. 40,000 whichever is less. Further the amount paid should also be reduced by the amount received if any under insurance from an insurerer or reimbursed by an employer. In case of a senior citizen (an individual resident in India who is of the age of sixty years or more at any time during the relevant previous year) the amount of deduction allowed is Rs. 60,000/-.

DDO must ensure that the employee furnishes a certificate in Form 10-I from a neurologist, an oncologist, a urologist, nephrologist, a haematologist, an immunologist or such other specialist, as mentioned in proviso rule 11(2) of the Rules.

For the purpose of this section in the case of an employee "dependant" means individual, the spouse, children, parents, brothers and sisters of the individual or any of them,

#### **5.5.9 Deduction in respect of interest on loan taken for higher education (Section 80E):**

Section 80E allows deduction in respect of repayment of interest on loan taken from any financial institution or any approved charitable institution for higher education for the purpose of pursuing his higher education or for the purpose of higher education of his spouse or his children or the student for whom he is the legal guardian.

The deduction shall be allowed in computing the total income for the Financial year in which the employee starts repaying the interest on the loan was taken and immediately succeeding seven Financial years or until the Financial year the interest is paid in full by the taxpayer, whichever is earlier.

For the purpose of this section -

- (a) "approved charitable institution" means an institution established for charitable purposes and approved by the prescribed authority section 10(23C), or an institution referred to in Section 80G(2)(a);
- (b) "financial institution" means a banking company to which the Banking Regulation Act, 1949 (10 of 1949) applies (including any bank or banking institution referred to in section 51 of that Act); or any other financial institution which the Central Government may, by notification in the Official Gazette, specify in this behalf;
- (c) "higher education" means any course of study pursued after passing the Senior Secondary Examination or its equivalent from any school, board or university recognized by the Central Government or State Government or local authority or by any other authority authorized by the Central Government or State Government or local authority to do so;

#### **5.5.10 Deductions on respect of donations to certain funds, charitable institutions, etc. (Section 80G):**

Section 80G provides for deductions on account of donation made to various funds , charitable organizations etc. In cases where employees make donations to the Prime Minister's National Relief Fund, the Chief Minister's Relief Fund or the Lieutenant Governor's Relief Fund through their respective employers, it is not possible for such funds to issue separate certificate to every such employee in respect of donations made to such funds as contributions made to these funds are in the form of a consolidated cheque. An employee who makes donations towards these funds is eligible to claim deduction under section 80G. It is, hereby, clarified that the claim in respect of such donations as indicated above will be admissible under section 80G on the basis of the certificate issued by the Drawing and Disbursing Officer (DDO)/Employer in this behalf- Circular No. 2/2005, dated 12-1-2005.

No deduction under this section is allowable in case of amount of donation if exceeds Rs. 10000/- unless the amount is paid by any mode other than cash.

#### **5.5.11 Deductions in respect of rents paid (Section 80GG):**

Section 80GG allows the employee to a deduction in respect of house rent paid by him for his own residence. Such deduction is permissible subject to the following conditions :-

- (a) the employee has not been in receipt of any House Rent Allowance specifically granted to him which qualifies for exemption under section 10(13A) of the Act;
- (b) the employee files the declaration in Form No. 10BA. (**Annexure VIII**)
- (c) He will be entitled to a deduction in respect of house rent paid by him in excess of 10% of his total

income, subject to a ceiling of 25% thereof or Rs. 2,000/- per month, whichever is less. The total income for working out these percentages will be computed before making any deduction under section 80GG.

(d) The employee does not own:

- (i) any residential accommodation himself or by his spouse or minor child or where such employee is a member of a Hindu Undivided Family, by such family, at the place where he ordinarily resides or performs duties of his office or carries on his business or profession; or
- (ii) at any other place, any residential accommodation being accommodation in the occupation of the employee, the value of which is to be determined under Section 23(2)(a) or Section 23(4)(a) as the case may be.

The Drawing and Disbursing Authorities should satisfy themselves that all the conditions mentioned above are satisfied before such deduction is allowed by them to the employee. They should also satisfy themselves in this regard by insisting on production of evidence of actual payment of rent.

#### **5.5.12 Deductions in respect of certain donations for scientific research or rural development (Section 80 GGA):**

Section 80GGA allows deduction from total income of employee in respect of donations of any sum as given in the Table below:

<i>Sl. No.</i>	<i>Donations made to persons</i>	<i>Approval /Notification under Section</i>	<i>Authority granting approval/ Notification</i>
1	To a research association which has as its object the undertaking of scientific research or to a University, college or other institution to be used for scientific research	u/s 35(l)(ii)	Central Government
2	To a research association which has as its object the undertaking of research in social science or statistical research or to a University, college or other institution to be used for research in social science or statistical research	u/s35(l)(iii)	Central Government
3	To an association or institution, which has as its object the undertaking of any programme of rural development, to be used for carrying out any programme of rural development approved for the purposes of section 35CCA	furnishes the certificate u/s 35CCA (2)	Prescribed Authority under Rule 6AAA
4	an association or institution which has as its object the training of persons for implementing programmes of rural development.	furnishes the certificate u/s 35CCA (2)	Prescribed Authority under Rule 6AAA
5	To a public sector company or a local authority or to an association or institution approved by the National Committee, for carrying out any eligible project or scheme.	furnishes the certificate u/s 35AC(2)(a)	National Committee for Promotion of Social & Economic Welfare
7	To a rural development fund	notified u/s 35CCA (1)(c)	set up and notified by the Central Government

8	To National Urban Poverty Eradication Fund	notified u/s 35CCA(l)(d)	set up and notified by the Central Government
---	--	--------------------------	---

No deduction under this section is allowable in case:

- (i) The employee has gross total income which includes income which is chargeable under the head "Profits and gains of business or profession".
- (ii) The amount of donation exceeds Rs. 10000 and is paid in cash.

The Drawing and Disbursing Authorities should satisfy themselves that all the conditions mentioned above are satisfied before such deduction is allowed by them to the employee. They should also satisfy themselves in this regard by insisting on production of evidence of actual payment of donation and a receipt from the person to whom donation has been made and ensure that the approval/notification has been issued by the right authority. DDO must ensure a self-declaration from the employee that he has no income from "Profits and gains of business or profession".

**5.5.13 Deduction in respect of interest on deposits in savings account (Section 80TTA):**

Section 80TTA has been introduced from this Financial Year [2012-13] and it allows to an employee from his gross total income if it includes any income by way of interest on deposits (not being time deposits) in a savings account a deduction amounting to :

- (i) in a case where the amount of such income does not exceed in the aggregate ten thousand rupees, the whole of such amount; and
- (ii) in any other case, ten thousand rupees.

If such savings account is maintained in a

- (a) banking company to which the Banking Regulation Act, 1949 (10 of 1949), applies (including any bank or banking institution referred to in section 51 of that Act);
- (b) co-operative society engaged in carrying on the business of banking (including a cooperative land mortgage bank or a co-operative land development bank); or
- (c) Post Office as defined in clause (k) of section 2 of the Indian Post Office Act, 1898 (6 of 1898),

For this section, "time deposits" means the deposits repayable on expiry of fixed periods.

**6. TDS on Payment of Accumulated Balance Under Recognised Provident Fund and Contribution from Approved Superannuation Fund:**

**6.1** The trustees of a Recognized Provident Fund, or any person authorized by the regulations of the Fund to make payment of accumulated balances due to employees, shall in cases where sub-rule(1) of Rule 9 of Part A of the Fourth Schedule to the Act applies, at the time when the accumulated balance due to an employee is paid, make therefrom the deduction specified in Rule 10 of Part A of the Fourth Schedule to the Act.

The accumulated balance is treated as income chargeable under the head "Salaries"

**6.2** Where any contribution made by an employer, including interest on such contributions, if any, in an approved Superannuation Fund is paid to the employee, tax on the amount so paid shall be deducted by the trustees of the Fund to the extent provided in Rule 6 of Part B of the Fourth Schedule to the Act. TDS should be at the average rate of tax, the employee was liable to be taxed during the preceding three years

or during the period, if that period is less than three years, when he was member of the fund.

The deductor shall remain liable to deduct tax on any sum paid on account of returned contributions (including interest, if any) even if a fund or part of a fund ceases to be an approved Superannuation fund.

## **7. DDOs to satisfy themselves about the genuineness of claim:**

The Drawing and Disbursing Officers should satisfy themselves about the actual deposits/ subscriptions / payments made by the employees, by calling for such particulars/ information as they deem necessary before allowing the aforesaid deductions. In case the DDO is not satisfied about the genuineness of the employee's claim regarding any deposit/ subscription/ payment made by the employee, he should not allow the same, and the employee would be free to claim the deduction/ rebate on such amount by filing his return of income and furnishing the necessary proof etc., therewith, to the satisfaction of the Assessing Officer.

## **8. Calculation Of Income-Tax To Be Deducted;**

**8.1** Salary income for the purpose of Section 192 shall be computed as follow:-

- (a) First compute the gross salary as mentioned in para 5.1 including all the incomes mentioned in para 5.2 and excluding the income mentioned in para 5.3.
- (b) Allow deductions mentioned in para 5.4 from the figure arrived at (a) above and compute the amount to arrive at Net salary of the employee
- (c) Add income from all other heads- House property, Profits & gains of Business or Profession, capital gains and Income from other Sources to arrive at the Gross Total Income as shown in the form of simple statement mentioned para 3.6. However it may be remembered that no loss under any such head is allowable by DDO other than loss under the Head "Income from House property".
- (d) Allow deductions mentioned in para 5.5 from the figure arrived at (c) above ensuring that the relevant conditions are satisfied. The aggregate of the deductions subject to the threshold limits mentioned in para 5.5 shall not exceed the amount at (b) above and if it exceeds, it should be restricted to that amount.

This will be the amount of Total income of the employee on which income tax would be required to be deducted. This income should be rounded off to the nearest multiple of ten rupees.

**8.2** Income-tax on such income shall be calculated at the rates given in para 2 of this Circular keeping in view the age of the employee and subject to the provisions of section 206AA, as discussed in para 4.8.

**8.3** The amount of tax payable so arrived at shall be increased by educational cess as applicable (2% for primary and 1% for secondary education) to arrive at the total tax payable.

**8.4** The amount of tax as arrived at para 8.3 should be deducted every month in equal instalments. Any excess or deficit arising out of any previous deduction can be adjusted by increasing or decreasing the amount of subsequent deductions during the same financial year.

## **9. MISCELLANEOUS:**

**9.1** These instructions are not exhaustive and are issued only with a view to guide the employers to understand the various provisions relating to deduction of tax from salaries. Wherever there is any doubt, reference may be made to the provisions of the Income-tax Act, 1961, the Income-tax Rules, 1962, the Finance Act, 2012 and the relevant circulars / notifications.

**9.2** In case any assistance is required, the Assessing Officer/the Local Public Relation Officer of the Income-tax Department may be contacted.

**9.3** These instructions may be brought to the notice of all Disbursing Officers and Undertakings including those under the control of the Central/ State Governments.

**9.4** Copies of this Circular are available with the Director of Income-tax(Research, Statistics & Publications and Public Relations), 6th Floor, Mayur Bhavan, Connaught Place, New Delhi-110 001 and at the following websites:

www.finmin.nic.in & www.incometaxindia.gov.in

### ANNEXURE-I

#### SOME ILLUSTRATIONS

##### Example 1

For Assessment Year 2013-14

(A) Calculation of Income tax in the case of an employee below the age of sixty years and having gross salary income of:

- (i) Rs. 1,50,000/-,
- (ii) Rs.2,00,000/-,
- (iii) Rs.5,00,000/-,
- (iv) Rs. 10,00,000/-and
- (v) Rs.20,00,000/-.

(B) What will be the amount of TDS in case of above employees, if PAN is not submitted by them to their DDOs/Offices:

<i>Particulars</i>	<i>Rupees (i)</i>	<i>Rupees (ii)</i>	<i>Rupees (iii)</i>	<i>Rupees (iv)</i>	<i>Rupees(v)</i>
Gross Salary Income (including allowances)	1,50,000	2,00,000	5,00,000	10,00,000	20,00,000
Contribution of G.P.F.	10,000	45,000	50,000	1,00,000	1,00,000

Computation of Total Income and tax payable thereon

<i>Particulars</i>	<i>Rupees (i)</i>	<i>Rupees (ii)</i>	<i>Rupees (iii)</i>	<i>Rupees (iv)</i>	<i>Rupees (v)</i>
Gross Salary	1,50,000	2,00,000	5,00,000	10,00,000	20,00,000
Less: Deduction U/s 80C	10,000	45,000	50,000	1,00,000	1,00,000
Taxable Income	1,40,000	1,55,000	4,50,000	9,00,000	19,00,000
(A) Tax thereon	Nil	Nil	25,000	1,10,000	4,00,000
Add:	Nil	Nil	500	250	8000
(i) Education Cess @ 2%.	Nil	Nil	2200	1100	4000

(ii) Secondary and Higher Education Cess @1%					
Total tax payable	Nil	Nil	25,750	1,13,300	4,12,000
(B) TDS under sec. 206AA in case where PAN is not furnished by the employee	Nil	Nil	90,000	1,80,000	4,12,000

### Example 2

For Assessment Year 2013-14

Calculation of Income Tax in the case of an employee below the age of sixty years having a handicapped dependent ( With valid PAN furnished to employer).

S.No.	Particulars	Rupees
1	Gross Salary	3,20,000
2	Amount spent on treatment of a dependant, being person with disability (but not severe disability)	7000
3	Amount paid to LIC with regard to annuity for the maintenance of a dependant, being person with disability( but not severe disability)	50,000
4	GPF Contribution 25,000	
5	LIP Paid	10,000

### Computation of Tax

S.No.	Particulars	Rupees
	1 Gross Salary	3,20,000
	Less: Deduction U/s 80DD (Restricted to Rs.50,000/- only)	50,000
	2 Taxable income	2,70,000
	Less: Deduction U/s 80C (i) GPF Rs.25,000/- (ii) LIP Rs. 10,000/- = Rs.35,000/-	35,000
3	Total Income	2,35,000
4	Income Tax thereon/payable	3,500
	Add:	
	(i). Education Cess @2%	70
	(ii). Secondary and Higher Education Cess @1%	35
5	Total Income Tax payable	3,605
6	Rounded off to	3,610

### Example 3

For Assessment Year 2013-14

Calculation of Income Tax in the case of an employee below age of sixty years where medical treatment expenditure was borne by the employer ( With valid PAN furnished to employer).

<i>S.No.</i>	<i>Articulars</i>	<i>Rupees</i>
1	Gross Salary	3,00,000
2	Medical Reimbursement by employer on the treatment of self and dependent family member	30,000
3	Contribution of GPF	20,000
4	LIC Premium	20,000
5	Repayment of House Building Advance	25,000
6	Tuition fees for two children	60,000
7	Investment in Unit-Linked Insurance Plan	20,000

#### Computation of Tax

<i>S.No.</i>	<i>Particulars</i>	<i>Rupees</i>
1	Gross Salary	3,00,000
	Add: Perquisite in respect of reimbursement of Medical Expenses In excess of Rs. 15,000/- in view of Section 17(2)(v)	15,000
2	Taxable income	3,15,000
	Less: Deduction U/s 80C	
	(i) GPF	Rs. 20,000/-
	(ii) LIC	Rs. 20,000/-
	(iii) Repayment of House Building Advance	Rs.25,000/-
	(iv) Tuition fees for two children	Rs. 60,000/-
	(v) Investment in Unit-Linked Insurance Plan	Rs. 20,000/-
	Total =Rs. 1,45,000/-	
	Restricted to Rs. 1,00,000/-	1,00,000
3	Total Income	2,15,000
4	Income Tax thereon/payable	1,500
	Add:	
	(i). Education Cess @2%	30
	(ii). Secondary and Higher Education Cess @1%	15
5	Total Income Tax payable	1,545
6	Rounded off to	1,550

#### Example 4

For Assessment Year 2013-14

Illustrative calculation of House Rent Allowance U/s 10 (13A) in respect of residential accommodation



situated in Delhi in case of an employee below the age of sixty years (With valid PAN furnished to employer).

<i>S.No.</i>	<i>Particulars</i>	<i>Rupees</i>
1	Salary	2,50,000
2	Dearness Allowance	1,00,000
3	House Rent Allowance	1,40,000
4	House rent paid	1,44,000
5	General Provident Fund	36,000
6	Life Insurance Premium	4,000
7	Subscription to Unit-Linked Insurance Plan	50,000

#### Computation of total income and tax payable thereon

<i>S.No.</i>	<i>Particulars</i>	<i>Rupees</i>
1	Salary + Dearness Allowance + House Rent Allowance 2,50,000+1,00,000+1,40,000 = 4,90,000	4,90,000
2	Total Salary Income	4,90,000
3	Less: House Rent allowance exempt U/s 10(13A):  Least of:  (a) Actual amount of HRA received= 1,40,000  (b) Expenditure of rent in excess of 10% of salary (including D.A. presuming that D.A. is taken for retirement benefit) (1,44,000-35,000) = 1,09,000  (c) 50% of Salary(Basic+ DA) = 1,75,000	1,09,000
	Gross Total Income	3,81,000
	Less: Deduction U/s 80C  (i) GPF Rs. 36,000/-  (ii) LIC Rs. 4,000/-  (iii) Investment in Unit-Linked Insurance Plan Rs. 50,000/-  Total =Rs.90,000/-	90,000
3	Total Income	2,91,000
	Tax payable on total income	9,100
	Add:  (i). Education Cess @2%  (ii). Secondary and Higher Education Cess @1%	182 91

Total Income Tax payable	9,373
Rounded off to	9370

### Example 5

For Assessment Year 2013-14

Illustrating valuation of perquisite and calculation of tax in the case of an employee below age of sixty years of a private company in Mumbai who was provided accommodation in a flat at concessional rate for ten months and in a hotel for two months ( With valid PAN furnished to employer).

S.No.	Particulars	Rupees
1	Salary	7,00,000
2	Bonus	1,40,000
3	Free gas, electricity, water etc. (Actual bills paid by company)	40,000
4(a)	Flat at concessional rate (for ten month). = Rs. 3,60,000	3,60,000
4(b)	Hotel rent paid by employer (for two month)	1,00,000
4(c)	Rent recovered from employee	60,000
4(d)	Cost of furniture.	2,00,000
5	Subscription to Unit Linked Insurance Plan	50,000
6	Life Insurance Premium	10,000
7	Contribution to recognized P.F.	42,000
8	Investment in long term infrastructure bonds (80CCF)	20,000

#### COMPUTATION OF TOTAL INCOME AND TAX PAID THEREON:

S.No.	Particulars	Rupees
1	Salary	7,00,000
2	Bonus	1,40,000
3	Total Salary(1+2) for Valuation of Perquisites	8,40,000
<b>Valuation of perquisites</b>		
4(a)	Perq. for flat: Lower of (15% of salary for 10 mnths.=Rs. 1,05,000/-) and (actual rent paid= Rs 3,60,000) Rs. 1,05,000 1,38,600	
4(b)	Perq for hotel : Lower of (24% of salary of 2 mnths.=Rs 33,600) and (actual payment= Rs 1,00,000) Rs. 33,600	
4(c)	Perquisites for furniture(Rs.2,00,000) @ 10% of cost 20,000	
4(c)(i)	Total of [4(a)+(b)+(c)] (1,05,000+ 33,600+ 20,000) Rs. 158,600 Less: rent recovered (-)Rs. 60,000 = Rs. 98,600	
4(d)	Add	
		Rs 1,38,600

	perq. for free gas, electricity, water etc. Rs.40,000 (+) Rs 98,600 [4(c)(i)] = Rs 1,38,600 Total perquisites	
5	Gross Total Income (Rs.8,40,000+ 1,38,600)	9,78,600
6	Gross Total Income	9,78,600
7	Less: Deduction U/s 80C & 80CCF: (i). Provident Fund (80C) :42,000 (ii) LIC (80C) :10,000 (iii) Subscription to Unit Linked Insurance Plan(80C) :50,000/- (iv) Investment in Infrastructure Bond(80CCF) :20,000 Total = 1,22,000 Restricted to Rs 1,00,000 u/s 80C and Rs 20,000 u/s 80CCF	1,20,000
8	Total Income	8,58,600
9	Tax Payable	1,01,720
10	Add: (i) Education Cess @2% (ii) Secondary and Higher Education Cess @1%	2,034 1,017
11	Total Income Tax payable	1,04,771
12	Rounded off to	1,04,770

### Example 6

For Assessment Year 2013-14

Illustrating Valuation of perquisite and calculation of tax in the case of an employee below the age of 60 years of a Private Company posted at Delhi and repaying House Building Loan ( With valid PAN furnished to employer)

S.No.	Particulars	Rupees
1	Salary	3,00,000
2	Dearness Allowance	1,00,000
3	House Rent Allowance	1,80,000
4	Special Duties Allowance	12,000
5	Provident Fund	60,000
6	LIP	10,000

7	Deposit in NSC VIII issue	30,000
8	Rent Paid by the employee for house hired by her	1,20,000
9	Repayment of House Building Loan (Principal)	60,000
10	Tuition Fees for three children (Rs. 10,000 per child)	30,000

Computation of total income and tax payable thereon

<i>S.No.</i>	<i>Particulars</i>	<i>Rupees</i>
1	Gross Salary (Basic+DA+HRA+SDA)	5,92,000
	Less: House rent allowance exempt U/s 10 (13A)	
	Least of:	
	(a). Actual amount of HRA received. :Rs. 1,80,000	
	(b). Expenditure on rent in excess of 10% of salary (Including D.A.)assuming D.A. is including for retirement benefits (1,20,000-40,000) :Rs. 80,000	
	(c). 50% of salary (including D.A) : Rs. 2,00,000	80,000
2	Gross Total Taxable Income 5,12,000	
	Less: Deduction U/s 80C	
	(i). Provident Fund : 60,000	
	(ii). LIP : 10,000	
	(iii). NSC VIII Issue : 30,000	
	(iv). Repayment of HBA : 60,000	
	(v). Tuition Fees (Restricted to two children) : 20,000	
	Total : 1,80,000	
	Restricted to 1,00,000	1,00,000
	Total Income	4,12,000
	Income Tax thereon/payable	21,200
	Add:	
	(i) Education Cess @ 2%	424
	(ii) Secondary and Higher Education Cess @ 1%	212
	Total Income Tax payable	21836
	Rounded off to	21840

**Example 7**

For Assessment Year 2013-14

A. Calculation of Income tax in the case of a retired employee above the age of sixty years but below the age of 80 years and having gross pension of:

i. Rs. 4,50,000/-,

ii. Rs. 8,00,000/-,

B. What will be the amount of TDS in case of above employees, if PAN is not submitted by them to their DDOs/Offices:

<i>Particulars</i>	<i>Rupees (i)</i>	<i>Rupees (ii)</i>
Gross Pension	4,50,000	8,00,000
Contribution of P.P.F.	70,000	70,000

Computation of Total Income and tax payable thereon

<i>Particulars</i>	<i>Rupees (i)</i>	<i>Rupees (ii)</i>
Gross Pension	4,50,000	8,00,000
Less: Deduction u/s 80C	70,000	70,000
Taxable Income	3,80,000	7,30,000
Tax thereon	13,000	71,000
Add:		
(i) Education Cess @ 2%.	260	1420
(ii) Secondary and Higher Education Cess @ 1%	130	710
Total tax payable	13,390	73,130
TDS under sec. 206AA in case where PAN is not furnished by the employee	26,000	1,46,000

### Example 8

For Assessment Year 2013-14

A. Calculation of Income tax in the case of a retired employee above the age of 80 years and having gross pension of:

iii. Rs. 4,50,000/-,

iv. Rs. 8,00,000/-,

B. What will be the amount of TDS in case of above employees, if PAN is not submitted by them to their DDOs/Offices:

<i>Particulars</i>	<i>Rupees (i)</i>	<i>Rupees (ii)</i>
Gross Pension	4,50,000	8,00,000
Contribution of P.P.F.	70,000	70,000

## Computation of Total Income and tax payable thereon

<i>Particulars</i>	<i>Rupees (i)</i>	<i>Rupees (ii)</i>
Gross Pension	4,50,000	8,00,000
Less: Deduction U/s 80C	70,000	70,000
Taxable Income	3,80,000	7,30,000
Tax thereon	Nil	46,000
Add:		
(i) Education Cess @ 2%.		920
(ii) Secondary and Higher Education Cess @ 1%		460
Total tax payable	Nil	47,380
TDS under sec. 206AA in case where PAN is not furnished by the employee	Nil	1,46,000

**Annexure-II**

Form No. 12BA

(See rule 26A(2)(b))

Statement showing particulars of perquisites, other fringe benefits or amenities and profits in lieu of salary with value thereof

(1) Name and address of employer :

(2) TAN

(3) TDS Assessment Range of the employer:

(4) Name, designation and PAN of employee :

(5) Is the employee a director or a person with :

substantial interest in the company (where the employer is a company)

(6) Income under the head "Salaries" of the employee :

(other than from perquisites)

(7) Financial Year :

(8) Valuation of Perquisites

<i>S. No</i>	<i>Nature of perquisite (see rule 3)</i>	<i>Value of perquisite as per rules (Rs.)</i>	<i>Amount, if any recovered from the employee (Rs.)</i>	<i>Amount of perquisite chargeable to tax Col(3) - Col(4) (Rs.)</i>

(1)	(2)	(3)	(4)	(5)
1.	Accommodation			
2.	Cars/Other automotive			
3.	Sweeper, gardener, watchman or personal attendant			
4.	Gas, electricity, water			
5.	Interest free or concessional loans			
6.	Holiday expenses			
7.	Free or concessional travel			
8.	Free meals			
9.	Free Education			
10.	Gifts, vouchers etc.			
11.	Credit card expenses			
12.	Club expenses			
13.	Use of movable assets by employees			
14.	Transfer of assets to employees			
15.	Value of any other benefit/amenity /service/privilege			
16.	Stock options (non-qualified options)			
17.	Other benefits or amenities			
18.	Total value of perquisites			
19.	Total value of Profits in lieu of salary as per 17(3)			

9. Details of tax, -

- (a) Tax deducted from salary of the employee u/s 192(1) .....
- (b) Tax paid by employer on behalf of the employee u/s 192(1A) .....
- (c) Total tax paid .....
- (d) Date of payment into Government treasury .....

**Declaration By Employer**

I..... s/o .....working as .....(designation) do hereby declare on behalf of ..... (name of the employer) that the information given above is based on the books of account, documents and other relevant records or information available with us and the details of value of each such perquisite are in accordance with section 17 and rules framed thereunder and that such information is true and correct.

Signature of the person responsible for deduction of tax

Place.....

Date .....

Full Name .....

Designation .....

### **Annexure-III**

F. No. SW/TDS/TIN/1/2010-DIT(S)-II

Directorate of Income-tax (System)

New Delhi

Revised Procedure

Furnishing of Quarterly e-TDS/TCS Statements by deductors/collectors

**1.1 Quarterly Electronic Statements Furnished Through TIN-FC: After preparing and validating the quarterly e-TDS/TCS, the deductor/collector shall furnish the same at any TIN-FC managed by NSDL. Deductor/collector shall ensure that:**

**1.1.1** Each quarterly e-TDS/TCS statement (Form 24Q, 26Q, 27Q and 27EQ) is in a separate computer media.

**1.1.2** Computer media to be used for furnishing e-TDS/TCS statements will be as defined by e-TDS Intermediary with approval of e-filing Administrator.

**1.1.3** Each quarterly e-TDS/TCS statement is accompanied by a duly filled and signed (by an authorized signatory) Form 27A in physical form.

**1.1.4** Each quarterly e-TDS/TCS statement is in one computer media, it should not span across multiple computer media.

**1.1.5** Quarterly e-TDS/TCS statement should be compressed, if required, only by using licensed version of Winzip 8.1 or ZipItFast 3.0 (or higher version) compression utility to ensure quick and smooth acceptance of the file.

**1.1.6** There is no overwriting/striking on Form 27A. If there is any, then the same should be ratified by an authorized signatory.

**1.1.7** No bank challan or copy of TDS/TCS certificate or physical copies of certificates or no/low deduction of TDS is required to be furnished along with the statements.

**1.1.8** TAN of deductor is mandatory to be mentioned in the statement. Statement shall not be accepted if TAN is not quoted.

**1.1.9** TAN details (name, address, etc..) of the deductor as provided in the quarterly e-TDS/TCS statement should be same as in the TAN database maintained by ITD (these details can be verified with the TIN-FC or the ITD web-site [www.incometaxindia.gov.in](http://www.incometaxindia.gov.in)). If they are different the deductor shall submit a TAN change request application to update the ITD TAN database or a copy of the acknowledgement of TAN change request already submitted.

**1.1.10** Each branch or Drawing and Disbursement Officer (DDO) of a deductor/collector furnishing separate quarterly e-TDS/TCS statement should furnish the quarterly e-TDS/TCS statement quoting separate TAN issued to each branch/DDO respectively.

**1.1.11** Quarterly e-TDS/TCS statement pertains to the period for which they are allowed to furnish.

**1.1.12** The quarterly e-TDS/TCS statement has been successfully validated through the latest version of the FVU.

**1.1.13** Control totals, TAN and name mentioned in the quarterly e-TDS/TCS statement match with those



mentioned on Form 27A.

**1.1.14** Computer media is virus free.

**Acceptance of Quarterly e-TDS/TCS Statements by e-TDS Intermediary (NSDL and TIN-FC branches)**

**2.1** Acceptance of Quarterly E-TDS/TCS Statement By TIN-FC: After deductor/collector furnishes the quarterly e-TDS/TCS statement to TIN-FC in the manner prescribed, TIN-FC will carry out format level validations and other checks to validate the quarterly e-TDS/TCS statement.

**2.1.1** Acceptance

**2.1.1.1** In case quarterly e-TDS/TCS statement is valid TIN-FC will issue a Provisional Receipt to the deductor/collector. The Provisional Receipt issued by TIN-FC to deductor/collector is deemed to be the proof of quarterly e-TDS/TCS statements furnished by the deductor/collector.

**2.1.1.2** Deductor/collector will pay upload fee along with service tax (as applicable - 10.20% at present) by demand draft or cash to the TIN-FC for every accepted quarterly e-TDS/TCS statement.

Maximum charges payable per quarterly e-TDS/e-TCS statement accepted:

<i>No. of Deductee Records in e-TDS/TCS Statement</i>	<i>Upload Charges</i>	<i>Upload Charges inclusive of service tax</i>
Upto 100 deductee records	Rs. 27.50/-	Rs. 30/-
101 to 1000 deductee records	Rs. 165/-	Rs. 182/-
More than 1000 deductee records	Rs. 550/-	Rs. 606/-

**2.1.1.3** TIN-FC will return the computer media containing the e-TDS/TCS statement to the deductor/collector

**2.1.1.4** TIN-FC will retain physical Form 27A along with other documents, if any, furnished by the deductor/collector. The retained physical Form 27A along with documents, if any, shall be stored by the TIN-FC for a period of one year from date of receipt of the statement.

**2.1.2** Non-Acceptance : TIN-FC will not accept the quarterly e-TDS/TCS statement furnished by deductor/collector if:

**2.1.2.1** each quarterly e-TDS/TCS statement (Form 24Q, 26Q, 27Q or 27EQ) is not furnished in a separate computer media along with duly filled and signed Form 27A in physical form;

**2.1.2.2** separate Form 27A is not quarterly e-TDS/TCS statement furnished for each striking and overwriting, if any, on Form 27A are not duly ratified by the person who has signed Form 27A;

**2.1.2.3** more than one quarterly e-TDS/TCS statement is furnished in one computer media;

**2.1.2.4** more than one computer media is used for furnishing one quarterly e- TDS/TCS statement;

**2.1.2.5** quarterly e-TDS/TCS statement is compressed using a compression utility other than winzip 8.1 or ZipItFast 3.0 (or higher version) compression utility;

**2.1.2.6** quarterly e-TDS/TCS statement is not in conformity with the file formats prescribed by ITD;

**2.1.2.7** TAN stated in quarterly e-TDS/TCS statement is not present in TAN Master database and deductor/collector does not submit any proof of TAN stated in the statement;

**2.1.2.8** deductor/collector does not have a TAN;

**2.1.2.9** name/address of deductor/collector displayed on TAN Master database does not match with name/address stated on Form 27A and deductor/collector does not provide TAN change request;

**2.1.2.10** mismatch of control totals as per with Form 27A and as per e-file;

**2.1.2.11** the quarterly statement has not been successfully passed through the latest version of FVU;

**2.1.2.12** Quarterly e-TDS/TCS statements do not pertain to the period for which deductors/collectors are allowed to submit their statements.

**2.1.2.13** Computer media is not virus free.

In such cases, TIN-FC shall issue a pre-printed Non - Acceptance Memo citing reasons for non-acceptance to the deductor/collector to carry out necessary corrections.

In case of non-acceptance, TIN-FC shall return the computer media as well as any other documents furnished and physical Form 27A to the deductor/collector.

No fee will be charged for the e-TDS/e-TCS statement that is not accepted.

**Annexure IV**

"Person Responsible for filing Form No. 24G in case of State Govt. Departments"

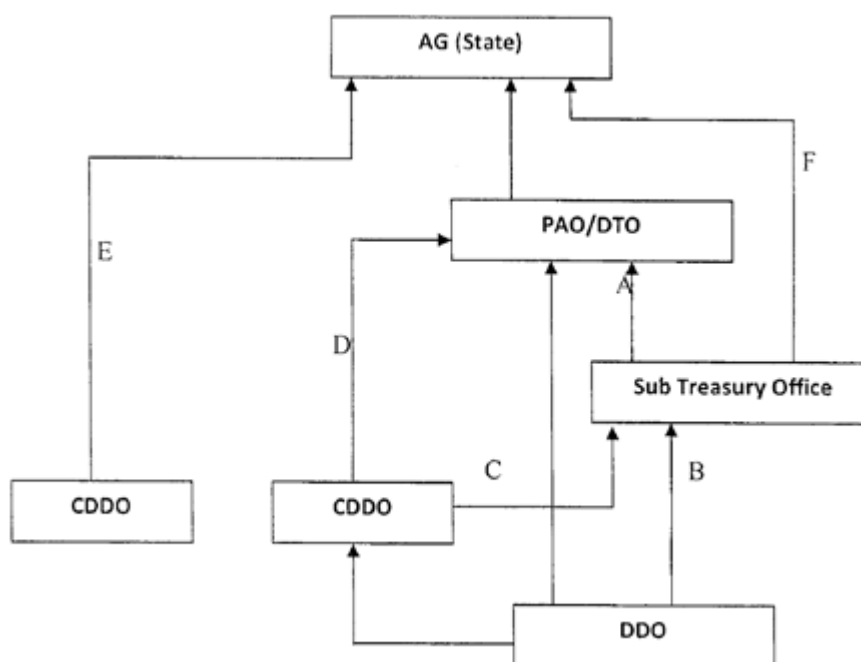

Type of Reporting of Book Entry	Person Responsible (AIN holder) for filing 24G.
A	PAO/DTO
B	PAO/DTO
C	PAO/DTO
D	PAO/DTO
E	CDDO
F	STO

AG	Accountant General
PAO	Pay & Accounts Officer
DTO	District Treasury Office
STO	Sub Treasury Office
DDO	Drawing & Disbursing Officer
CDDO	Cheque Drawing & Disbursing Officer

"Person Responsible for filing Form No. 24G in case of Central Govt. Departments"

ZAO/PAO of Central Government Ministries is responsible for filing of Form No. 24G on monthly basis

FURNISHING OF MONTHLY FORM NO. 24G STATEMENTS BY PAY AND ACCOUNTS OFFICERS (PAOs)/DISTRICT TREASURY OFFICERS (DTOs)/CHEQUE DRAWING AND DISBURSING OFFICERS(CDDOs)

### **1. Under what income tax rule should Form 24G be filed?**

Income-tax Department Notification no. 41/2010, dated May 31, 2010 amended the Income Tax Rule 30 which mandates that in case of an office of the Government, where tax has been paid to the credit of Central Government without the production of a challan (associated with deposit of the tax in a bank), the relevant PAO / CDDO / DTP or an equivalent office of the Government (herein after called as AO in this document) is required to file Form 24G on monthly basis.

### **2. Who is the relevant PAO/CDDO/DTO who is liable for filing Form 24G?**

A relevant PAO/CDDO/DTO is that office to whom the Deductor/DDO (TAN holder) reports remittance of TDS/TCS through book adjustment. Generally, the Central Government DDOs report TDS through book entry to their respective Pay and Accounts Officers (PAOs) and the State Government DDOs report TDS through book entry to their respective District Treasury Officers(DTOs). Such PAOs and DTOs are required to file Form 24G on monthly basis.

There are also cases of Cheque Drawing and Disbursing Officers (CDDOs) who report TDS through book entry directly to State AG. For example, PWD, Forest Department etc. Such CDDOs are also required to file Form 24G on monthly basis. Schematic Diagram at Annexure-IV clarifies the person responsible for filing Form 24G in different scenarios.

### **3. Can the same office/officer also act as DDO and AO?**

Ordinarily, the PAO office is the one to whom the DDO reports the TDS and therefore, both should be from different offices. However, where the DDO and AO are the same, as in the case of CDDOs, the statistics report of Form 24G should be counter signed by his superior officer.

### **4. What is AIN and who should apply?**

Accounts Office Identification Number (AIN) is a unique seven digit which is allotted by the Directorate of Income Tax (Systems), Delhi, to every AO. Each AO is uniquely identified in the system by this number. AOs are required to apply for AIN with jurisdictional TDS office. The AIN application can be downloaded from TIN site. Every AIN holder is required to file Form 24G.

Each DDO is identified in the system by a Tax Deduction and Collection Account Number (TAN). This number is allotted by Income Tax Department.

## **5. Where should the Accounts Office Identification Number (AIN) application be submitted ?**

The duly filled and signed application for AIN allotment is to be submitted in physical form by the PAO / CDDO / DTO to the jurisdictional CIT (TDS). Complete and correct AIN application forms will be forwarded by the jurisdictional CIT (TDS) to National Securities Depository Limited (NSDL), Tradeworld, A Wing, 4th Floor, Kamala Mills Compound, Lower Parel, Mumbai 400 013 recommending allotment of AIN to the PAO / CDDO / DTO.

## **6. What information should be submitted through Form 24G?**

Every AO should furnish one complete, correct and consolidated Form 24G every month having details of each type of deduction / collection separately viz. TDS-Salary / TDS-Non Salary / TDS-Non Salary Non-Residents / TCS made by each DDO under his jurisdiction.

## **7. Where should Form 24G be submitted?**

Form 24G is to be furnished only in electronic form in a CD/pen drive at TFN-FCs or online through AO Account at [www.tin-nsdl.com](http://www.tin-nsdl.com) web portal. The facility to submit Form No. 24G online is available free of cost. Provisional Receipt Number (PRN) is issued as an acknowledgement of the receipt of Form 24G.

## **8. How to register for online facility?**

Registration for AO Account is mandatory for filing Form No. 24G online through TIN website, [vwww.tin-nsdl.com](http://vwww.tin-nsdl.com). Registration AO Account is required once only. AO required to submit the Form No. 24G at TIN-FC at least once to comply with the Know Your Customer (KYC) norms for registration of the AO Account. After registration, it is optional for AO either to submit the Form No.24G in CD/Pen drive at TIN-FC or online.

## **9. What are the functionalities available with AO Account?**

Through the AO Account, the AO can view the status of Form No. 24G filed, obtain BIN (Book Identification Number) details, update AO profile and upload Form No. 24G. The status tracking is based on AIN and concerned Provisional Receipt Number (PRN) of Form 24G.

## **10. Can the AO furnish Form No. 24G in paper form?**

No. Form 24G is to be filed only in electronic form.

## **11. Can the AO submit the electronically prepared Form No.24G at the Income Tax Office?**

No. Electronically prepared Form No.24G can only be submitted at TIN-FC or online .

## **12. What does Form 24G contain?**

Every Form 24G should be prepared in accordance with the data structure prescribed by the Income Tax Department (ITD). Form 24G contains-

- Details of the AO filing Form 24G (AIN, name, demographic information, contact details).
- Category of AO (Central / State Government) along with details of ministry / state.
- Statement details (month and year for which Form 24G is being filed).
- Payment summary; nature of deduction wise (TDS - Salary /TDS Non-salary / TDS -Non-salary Non-resident / TCS).
- DDO wise payment details (TAN of DDO, name, demographic details, total tax deducted and

remitted to the Government account (A.G. / Pr.CCA).

- DDOs which are associated with the AO. If the DDO wants to add/delete or update details of DDO, same should be mentioned in the statement.

### **13. What is the procedure to prepare the Form 24G statement?**

The AO can prepare the statement using the Form 24G Preparation Utility developed by National Securities Depository Limited (NSDL) and freely available at Tax Information Network (TIN) website ([www.tin-nsdl.com](http://www.tin-nsdl.com)) or ITD website ([www.incometaxindia.gov.in](http://www.incometaxindia.gov.in)).

Once the statement is prepared, the AO shall validate the same by using File Validation Utility (FVU) developed by NSDL and freely available at the TIN or ITD website. The statement can be furnished in Compact Disk (CD) at any of the TIN-Facilitation Centers (TIN-FC) managed by NSDL along with Form 24G Statement Statistics Report (generated through File Validation Utility), duly signed by the AO. The list of TIN-FCs is available at TIN or ITD website.

Once Form 24G is accepted by the TIN-FC, it will issue a provisional receipt with a unique Provisional Receipt Number (PRN) to the AO as a proof of submission of the statement.

### **14. What is Form 24G Preparation Utility?**

The Form 24G Preparation Utility is a Java based utility. Form 24G Preparation Utility can be freely downloaded from [www.tin-nsdl.com](http://www.tin-nsdl.com). After downloading, it needs to be saved on the local disk of the machine.

JRE (Java Run-time Environment) [versions: SUN JRE: 1.4.2\_02 or 1.4.2\_03 or 1.4.2\_04 or IBM JRE: 1.4.1.0] should be installed on the computer where Form 24G Preparation Utility is being installed. JRE is freely downloadable from <http://java.sun.com> and

<http://www.ibm.com/developerworks/java/ide/> or you can ask your computer vendor (hardware) to install the same for you.

Form 24G Preparation Utility can be executed on Windows platform(s) Win 2K Prof. / Win 2K Server/ Win NT 4.0 Server/ Win XP Prof. To run the 'Form 24G Preparation Utility', click on the '24GRPU.bat' file.

If JRE is not installed on the computer, then on clicking '24GRPU.bat', a message will be displayed. In such cases, install JRE and try again. If appropriate version of JRE is installed, then the 'Form 24G Preparation Utility' will be displayed.

### **15. What are the steps to download and install Form 24G Preparation Utility?**

For assistance in downloading and using Form 24G Preparation Utility, please read the instructions provided in 'Help' in the Form 24G Preparation Utility. This utility can be used for preparation of Form 24G with up to 75,000 records. Form 24G Preparation Utility (version 1.2) should be used for regular and correction statements.

### **16. What is File Validation Utility (FVU)?**

The AO should pass the Form 24G (Regular/Correction) file generated using Preparation Utility through the File Validation Utility (FVU) to ensure format level accuracy of the file. This utility is also freely downloadable from TIN website. In case the Form 24G contains any errors, the AO should rectify the same. After rectifying the errors, user should pass the rectified Form 24G through the FVU. This process should be continued till an error-free Form 24G is generated. Form 24G (regular/correction) prepared from F.Y. 2005-06 onwards can be validated using this utility.

The Form 24G FVU is a Java based utility. JRE (Java Run-time Environment) [versions: SUN JRE: 1.4.2\_02 or 1.4.2\_03 or 1.4.2\_04 or IBM JRE: 1.4.1.0] should be installed on the computer where the Form 24G FVU is being installed. JRE is freely downloadable from <http://java.sun.com> and <http://www.ibm.com/developerworks/java/ide/> or you can request your computer vendor (hardware) to install the same for you.

The Form 24G FVU setup comprises of two files, namely-

- Form 24G FVU.bat: This is a setup program for installation of FVU.
- Form 24G\_FVU\_STANDALONE.jar: This is the FVU program file.

These files are in an executable zip file (Form24GFVU.exe) (version 1.2). These files are required for installing the Form 24G FVU.

Instructions for extracting and setup are given in:

- Form 24G FVU Extract and Setup

**17. After preparation of Form No. 24G statement through RPU, three files are generated when such statement passes through FVU. Is the AO required to take all three files in CD /PAN drive to TIN-FC?**

When a valid file is passed through the FVU, the following three files are generated:-

- (a) The upload file
- (b) Form 24G statement Statistics Report and
- (c) Form 24G.

Every Form 24G (upload file) mentioned at Sr. No. (a) is to be saved in CD and the same should be accompanied with the Statement Statistic Report mentioned at Sr. No. (b), in paper form duly signed by the Accounts Officer, which needs to be submitted at TIN-FCs.

Form 24G: Form 24G, at serial number (c) above, is a reader friendly format of TDS/TCS Book Adjustment form. This is like the physical form of Form 24G in html format. It contains all the details of Accounts Officer as well as Drawing and Disbursement Officer. There is no need to submit this file.

**18. Can the Form 24G Statement be corrected?**

Every Form 24G is to be prepared in accordance with the data structure prescribed by the Income Tax Department (ITD). If it does not conform to the new data structure it will be rejected by TIN.

As per procedure, statements relating to Form 24G should be complete and correct. No fragmented statements are expected to be filed (i.e. separate statements giving details for deductions under different form type with respect to the same AIN, FY and month). However, any mistake made in an original accepted statement can be rectified by submitting a 'correction statement'. For correction, the latest version of the RPU should be downloaded from TIN website.

Form 24G corrections can also be uploaded directly at the TIN website. For direct upload at TIN Central system, AO has to first register AIN at TIN website and upload the Form 24G correction.

**19. What are the different kinds of correction statements allowed?**

There are two different types of correction statements that can be furnished by the AO. These are listed below.

- M (Modify) -: For any modification in the existing Form 24G statement.
- X (Cancel) -: For cancellation of an existing Form 24G statement.

For preparation of correction statement, the receipt number of the original statement and receipt number of the previous statement is mandatory.

In case of first correction, PRN of original statement should be provided in field "Receipt number of Original Statement" and also in the field "Receipt number of Previous Statement".

In case a correction statement has already been filed earlier, PRN of original statement should be provided in field "Receipt number of Original Statement" and PRN of last correction to be mentioned in field "Receipt number of Previous Statement".

## **20. What is M -Type of Correction Statement?**

This type of correction statement is to be furnished by AO, if it wishes to update any of its details like its name, address, Responsible person details, category, Ministry, State or deletion and addition of DDO (Drawing & Disbursing Officer) etc. Modifications in AIN (Account office Identification Number), Financial Year and Month are not allowed.

There are three modes by which changes can be made in the DDO details provided in original Form 24G statement:

- Add: DDO records can be added to the original Form 24G statement
- Update: details of DDO (i.e. TAN, TAN Name, demographic and contact details, amount of tax deducted and remitted, nature of deduction) can be updated for the DDO records provided in original or subsequent correction statement
- Delete: DDO records provided in original Form 24G or subsequent correction statement can be deleted

M-type correction statement will always contain AO details and details of DDO which are added and/or deleted.

## **21. What is X-Type of Correction Statement?**

This type of correction statement is to be furnished by AO if it wishes to cancel an existing Form 24G statement. Filing of Correction type X will allow AOs to file regular Form 24G for the same primary key (AIN, Financial year and Month). This type of correction is to be filed only if the Form 24G has been filed with wrong AIN or, F.Y. or Month.

## **22. What is BIN?**

BIN stands for "Book Identification Number" for each form type mentioned in the accepted monthly form No. 24G. BIN consists of the following:

- (i) Receipt Number: Receipt number is a seven digit unique number generated on successful acceptance of Form 24G.
- (ii) DDO Serial Number: It is a five digit unique number generated for every DDO transaction reported in Form 24G statement.
- (iii) Transfer Voucher Date: It is the last date of month for which Form 24G statement is filed.

BIN is required to be disseminated to the respective DDOs who in turn are required to report the same in

the TDS/TCS Statement. The quoting of BIN has been made mandatory w.e.f 1 February, 2012. BIN is a unique number to verify the claim of TDS deposited without production of challan. As it is a verification key, it is advised that valid BIN disseminated by AO to the respective DDO should be correctly filled in TDS statement.

### **23. When is BIN generated?**

On processing of accepted Form 24G statement, BIN is generated for each DDO record (with valid TAN) present in Form 24G statement. BIN are generated at TIN Central System and intimated to the PAOs with details of TAN and Form Type. DDOs can also download the same from TIN portal after TAN registration with TIN portal for online view.

### **24. What do the PAO and DDO have to do with the BIN?**

PAOs have to disseminate the BINS to respective DDOs. While preparing the quarterly TDS/TCS statement, DDO has to quote the said BIN details, if tax has been paid through transfer voucher (book adjustment).

BINs generated for a particular 24G are mailed to the AO on the e-mail id provided in Form 24G. In addition, AO may also download the BIN details through AO login at TIN site. The DDOs can obtain the respective BIN either from PAO directly or can download from the TIN website [www.tin-nsdl.com](http://www.tin-nsdl.com) through the TAN account. Detailed procedure for registration of TAN on the TIN website and download of BIN is available on the TIN website as referred to above.

### **25. Under what circumstances will BIN be generated?**

- BIN will be generated for valid TAN-DDO records added in Form 24G correction statement
- BIN will be generated for DDO records where invalid TANs/TAN not present in Income Tax Department database is updated with a valid TAN.
- New BIN will not be generated for any update made in TAN name, demographic and contact details, amount of Tax deducted and remitted or nature of deduction.
- BIN details will not be generated for deleted DDO records.

### **26. What is the utility of BIN?**

The BIN details and amount of TDS reported in the quarterly TDS/TCS Statement filed by the DDO will be matched with the respective details filed in Form No.24G filed by the PAO at TIN Central System for accepting TDS/TCS Statement and for verification purpose.

### **27. Are there instances where BIN details and amount of TDS reported in TDS/TCS statements do not match with that reported in Form 24G? What are the consequences of such mismatch?**

- (i) Instances of wrong/incorrect reporting of BIN by the DDOs in the TDS/TCS Statement have been observed. Reporting of incorrect BINs and corresponding amount in TDS statement will lead to mismatch with the respective amount as reported in the Form No. 24G. In this situation, the corresponding deductees may not get credit of the TDS/TCS. Therefore, the BIN as disseminated by the respective PAO should be reported correctly along with the corresponding amount in the TDS/TCS Statement filed by the DDOs.
- (ii) In a number of cases, one distinct DDO has been found to be reported by more than one AO in the Form No. 24G for the same form type of TDS statement which is not a valid scenario. The DDOs and respective AOs are advised to reconcile the issue and one DDO should be mapped to one AO only for a particular form type for a particular month.



## **28. What are the duties of PAOs/DTOs/CDDOs?**

- i.* To apply for AIN with jurisdictional TDS office. AIN application can be downloaded from TIN site.
- ii.* To obtain correct TAN from the reporting DDOs.
- iii.* To file Form No. 24G (in CD, DVD, Pen Drive), within 10 days from the end of the month, electronically either at TIN-FC or by direct online upload at TIN website.
- iv.* To track status of the filed Form No. 24G through TFN website.
- v.* To download Book Identification Number (BIN) generated on the basis of 24G statement.
- vi.* To disseminate BIN to the respective DDOs.

## **29. What are the duties of DDOs?**

- i.* To provide correct TAN to their PAOs/DTOs/CDDOs to whom the DDO/Deductor reports the tax so deducted & who is responsible for crediting such sum to the credit of the Central Government.
- ii.* To report to PAOs/DTOs/CDDOs, the details of tax deducted and credited to the Central Government account through book adjustment.
- iii.* To quote BIN in the quarterly TDS/TCS Statement (24Q, 26Q, etc) for the tax deducted and credited through book adjustment.

## **30. What are the consequences of non-quoting of BIN details in quarterly TDS/TCS statement?**

- (a)* BIN details and amount of TDS reported in the quarterly TDS/TCS Statement filed by the DDO will be matched with the details filed in Form No.24G filed by the PAO at the TIN Central System for accepting TDS/TCS Statement and for verification purpose.
- (b)* Any wrong information reported by the DDOs in TDS/TCS Statement may lead to mismatch in the TIN Central System due to which credit to the respective deductee will not be "finally booked" in the deductee's Form 26AS.
- (c)* Further details are available at TIN website [www.tin-nsdl.com](http://www.tin-nsdl.com) and ITD website [www.incometaxindia.gov.in](http://www.incometaxindia.gov.in).

### **ANNEXURE-V**

#### **MINISTRY OF FINANCE**

(Department of Economic Affairs)

(ECB & PR Division)

#### **NOTIFICATION**

New Delhi, the 22nd December, 2003

F. No. 5/7/2003-ECB &PR- The government approved on 23rd August, 2003 the proposal to implement the budget announcement of 2003-04 relating to introducing a new restructured defined contribution pension system for new entrants to Central Government service, except to Armed Forces, in the first stage, replacing the existing system of defined benefit pension system.

- i.* The system would be mandatory for all new recruits to the Central Government service from 1st of January, 2004 (except the armed forces in the first stage). The monthly contribution would be 10 per

cent of the salary and DA to be paid by the employee and matched by the Central Government. However, there will be no contribution from the Government in respect of individuals who are not Government employees. The contribution and investment returns would be deposited in a non-withdrawable pension tier-I account. The existing provisions of defined benefit pension and GPF would not be available to the new recruits in the Central Government service.

- ii. In addition to the above pension account, each individual may also have a voluntary tier-II withdrawable account at his option. This option is given as GPF will be withdrawn for new recruits in Central Government service. Government will make no contribution into this account. These assets would be managed through exactly the above procedures. However, the employee would be free to withdraw part or all of the Rs. second tier' of his money anytime. This withdrawable account does not constitute pension investment, and would attract no special tax treatment.
- iii. Individuals can normally exit at or after age 60 years for tier-I of the pension system. At the exit the individual would be mandatorily required to invest 40 per cent of pension wealth to purchase an annuity (from an IRDA- regulated life insurance company). In case of Government employees the annuity should provide for pension for the lifetime of the employee and his dependent parents and his spouse at the time of retirement. The individual would receive a lump-sum of the remaining pension wealth, which he would be free to utilize in any manner. Individuals would have the flexibility to leave the pension system prior to age 60. However, in this case, the mandatory annuitisation would be 80% of the pension wealth.

#### **Architecture of the new Pension System**

- (i) It will have a central record keeping and accounting (CRA) infrastructure, several pension fund managers (PFMs) to offer three categories of schemes *viz.* option A, B and C.
  - (ii) The participating entities (PFMs and CRA) would give out easily understood information about past performance, so that the individual would be able to make informed choices about which scheme to choose.
2. The effective date for operationalization of the new pension system shall be from 1st of January, 2004.

#### **ANNEXURE-VI**

MINISTRY OF FINANCE

(Department of Revenue)

(Central Board of Direct Taxes)

Notification

New Delhi, the 24th November, 2000

#### **INCOME- TAX**

S.O.1048 (E) - In exercise of the powers conferred by sub-clause (i) of clause (18) of Section 10 of the Income-tax Act, 1961 (43 of 1961), the Central Government, hereby specifies the gallantry awards for the purposes of the said Section, mentioned in column 2 of the table below awarded in the circumstances as mentioned in corresponding column 3 thereof. -

**TABLE**

<i>Sl. No.</i>	<i>Name of gallantry award</i>	<i>Circumstances for eligibility</i>
----------------	--------------------------------	--------------------------------------

(1)	(2)	(3)
1.	Ashok Chakra	When awarded to Civilians for gallantry
2.	Kirti Chakra	-do-
3.	Shaurya Chakra	-do-
4.	Sarvottan Jeevan Raksha Padak	When awarded to Civilians for bravery displayed by them in life saving acts.
5.	UttamJeevanRaksha Medal	-do-
6.	JeevanRakshaPadak	-do-
7.	President's Police Medal for gallantry	When awarded for acts of exceptional courage displayed by members of police forces, Central police or security forces and certified to this effect by the head of the department concerned
8.	Police Medal for Gallantry	-do-
9.	Sena Medal	When awarded for acts of courage or conspicuous gallantry and supported by certificate issued to this effect by relevant service headquarters.
10.	NaoSena Medal	-do-
11.	VayuSena Medal	-do-
12.	Fire Services Medal for Gallantry	When awarded for acts of courage or conspicuous gallantry and supported by certificate issued to this effect by the last Head of Department.
13.	President's Police & Fire Services Medal for Gallantry	-do-
14.	President's Fire Services Medal for Gallantry	-do-
15.	President's Home Guards and Civil Defence Medal for Gallantry	-do-
16.	Home Guard and Civil Defence Medal for Gallantry	-do-

(Notification no. 1156/F.No. 142/29/99-TPL)

## ANNEXURE VII

MINISTRY OF FINANCE

Department of Revenue

Central Board of Direct Taxes

New Delhi, the 29th January, 2001

S.O.81(E)- In exercise of the powers conferred by sub-clause (i) of clause (18) of Section 10 of the Income -tax Act, 1961 (43 of 1961)), the Central Government, hereby specifies the gallantry awards for the purposes of the said Section and for that purpose makes the following amendment in the notification

of the Government of India in the Ministry of Finance, Department of Revenue (Central Board of Direct Taxes) number S.O.1048(E), dated the 24th November, 2000, namely:-

In the said notification, in the Table, against serial numbers 1,2 and 3 under cloumn (3) relating to "Circumstances for eligibility" the words "to civilians" shall be omitted.

(Notification No.22/F.No.142/29/99-TPL)

**ANNEXURE-VIII**

FORM NO. 10BA

(See rule 11B)

**DECLARATION TO BE FILED BY THE ASSESSEE**

**CLAIMING DEDUCTION U/S 80 GG**

I/We.....

(Name of the assessee with permanent account number)

do hereby certify that during the previous Year.....I/We had occupied the premise.....(full address of the premise) for the purpose of my/our own residence for a period of.....months and have paid Rs..... In cash/through crossed cheque, bank draft towards payment of rent to Shri/Ms /M/s.....(name and complete address of the landlord).

It is further certified that no other residential accommodation is owned by

- (a) me/my spouse/my minor child/our family (in case the assessee is HUF), at .....where I/we ordinarily reside/perform duties of officer or employment or carry on business or profession, or
- (a) me/us at any other place, being accommodation in my occupation, the value of which is to be determined u/s 23(2)(a)(i) of u/s 23(2)(b).

■ ■